



Institute for Advanced Study
Math. - Nat. Sci. Library
Princeton, N. J. 08540

1
" ECP
Interim

INTERIM PROGRESS REPORT
ON THE
PHYSICAL REALIZATION OF AN
ELECTRONIC COMPUTING INSTRUMENT

BY

Julian H. Bigelow

James H. Pomerene

Ralph J. Slutz

Willis H. Ware

Institute for Advanced Study
1 January 1947

RECEIVED
JAN 10 1947

IAS ECP list of reports,
1946-57. no. 3.

PREFACE

The ensuing interim report has been prepared in accordance with the terms of Contract W-26-034-ORD-7481 between Research and Development Service, Ordnance Department, U. S. Army and the Institute for Advanced Study. The express purpose of this report is to furnish contemporary advice to the Service regarding steps taken and contemplated toward the realization of an electronic computing instrument embodying the principles outlined in the Institute for Advanced Study report, dated 28 June 1946, entitled, "Preliminary Discussion of the Logical Design of an Electronic Computing Instrument", by Burks, Goldstine and von Neumann.

The experimental techniques, component types, schemes for synthesis of primary organs as well as the underlying philosophy of realization indicated in this report should be understood as wholly tentative; and are subject to revision from time to time either in detail or in their entirety as the work progresses.

J. H. B.

J. H. P.

R, J. S.

W. H. W.

*45012

TABLE OF CONTENTS

I. REMARKS ON ORGANIZATION

I.1	Outline of Objective	1
I.2	Program of Experimentation, Design and Construction	2
I.3	Facilities	2
I.4	Aid from Cooperative Outside Groups	3
I.5	Personnel	4
I.6	Dates and Program of Accomplishment	4

II. GENERAL DISCUSSION OF COMPUTER

II.1	Definitions: Organs, Components, Elements	6
II.2	Block Diagram	6
II.3	Organs and Functions	7
II.31	Terminal (Input-Output)	7
II.32	Memory (Inner and Outer)	8
II.33	Arithmetic Organ A	9
II.34	Control Organ C	10
II.4	Components	11
II.5	Elements	12
II.6	Philosophy of Choice	13
II.61	Criteria of Speed	13
II.62	Criteria of Certainty	14
II.63	Interdependence, Simplicity	14
II.64	Energy and Compactness	16
II.7	Beliefs with Undefined Side Conditions	17
II.71	Amplitude vs. Time Sensitivity	17
II.72	Information Transfer as a Function of Interval	18
II.73	Pulsers, Clocks, Closed Cyclers	18
II.74	Checking Processes	19

TABLE OF CONTENTS (cont'd)

<u>III. REMARKS ON THE REALIZATION OF LARGE MEMORY CAPACITY</u>		
III.1	Discussion of Performance Criteria	20
III.11	Information Storage per Unit Volume	20
III.12	Inscription Speed Range	20
III.13	Reproduction Speed Range	20
III.14	Accessibility	21
III.15	Verifiability	21
III.16	Erasability	21
III.17	Permanence	21
III.18	Durability	21
III.19	Convenience and Economy	22
III.2	Media and Energy Storage	22
III.21	Energy Level: Fundamental Role of Non-Linearity	24
III.22	Memory Transfer: Amplification	24
III.23	Sensitivity Ratio Criteria	25
III.3	Cellular and Continuous Media	25
III.31	Problem of Scanning	25
III.32	Problem of Registration	26
III.33	Three-Dimensional Continuous Media	27
III.34	Two-Dimensional Continuous Media	27
III.35	One-Dimensional Continuous Media	27
III.4	Various "Magnetic Ribbons"	28
III.41	Performance Criteria; Head Design, Orientation, Amplification.	29
III.42	Density of Information	29
III.43	Positive and Negative Sequences: Signal Integration	29
III.44	Inscription Speed Range	30
III.45	Reproduction Speed Range	31
III.46	Durability and Wear	31
III.47	Retentivity	31
III.48	Coercive Force	32
<u>IV. MAGNETIC RIBBON EXPLORATION: TEST APPARATUS</u>		
IV.1	Low Speed Loop Sample Comparator	33
IV.2	High Speed Magnetic Performance Tester (Pfortus)	34
IV.3	High Speed Mechanical Drive Tester	35

TABLE OF CONTENTS (cont'd)

IV.4	Recording Head Booster Amplifier	37
IV.5	Pulsed-Word Generator	38
<u>V. MAGNETIC RIBBON EXPLORATION: PERFORMANCE STUDIES</u>		
V.1	Comparison of Magnetic Properties at Low Speed	39
V.11	Retentivity	39
V.12	Coercive Force	40
V.13	Packing Density	40
V.2	High Speed Magnetic Performance	42
V.21	Inscription Speed Range	42
V.22	Reproduction Speed Range	43
V.23	Packing Density	43
V.24	Output Level and Amplification Required	43
V.25	Effects of Head Design: Saturation Phenomena	44
V.26	Signal to Noise Level	44
V.27	Fatigue and Durability	44
V.3	High Speed Mechanical Performance	45
V.31	Packing on Reel	45
V.32	Tension on Recording Head	45
V.33	Travel Speed	45
V.34	Acceleration and Reversal	45
V.35	Vibration	46
V.36	wear and Fatigue	46
V.37	Knotted Splices	46
V.38	Electrical Output Performance	46
V.39	Effect of Dirt and Cleanliness	47
<u>VI. OUTER MEMORY COMPONENT DESIGN STUDIES</u>		
VI.1	Component Overall Size, Capacity, Proportions	48
VI.11	Drive Scheme	48
VI.12	Reel Design	49
VI.13	Loop Tension	49
VI.14	Run and Reversal Speeds	49
VI.15	Head Design	50
VI.16	Breakage Repair	50
VI.17	Automatic Control	50

MEMORANDUM

TO : [Illegible]

[Illegible body text]

DATE: [Illegible]

1
2
3
4
5
6
7
8
9
10
11
12
13
14
15
16
17
18
19
20
21
22
23
24
25
26
27
28
29
30

TABLE OF CONTENTS (cont'd)VII. INPUT-OUTPUT TRANSCRIBER COMPONENT STUDIES

VII.1	Registration on Ribbon Media	52
	VII.11 Requirement of Asynchronous Operation	52
	VII.12 Sequential Coding: Markers vs. Blanks	54
	VII.13 Coding by Index Numbers vs. Counting Markers	55
VII.2	Types of Fault: Risk	56
	VII.21 Disclosed Faults	56
	VII.22 Undisclosed Faults	57
	VII.23 Systematic Faults and Random Errors	57
	VII.24 Element Failures	58
	VII.25 Noise Level; Pickup; Stray Coupling	58
	VII.26 Positive Action Checking	59
	VII.27 Coincident Faults	61
	VII.28 Minimization of Overall Risk	62
VII.3	A Workable Rudimentary Keyboard to Ribbon Transcriber	62
	VII.31 Capabilities of the Type 19 Set.	62
	VII.32 Simple Modification to Type 19 Teletype Set	63
	VII.33 Practical Operation of Rudimentary Type 19 Transcriber	63
	VII.34 Crude Overall Checking and Error Correction	64
VII.4	A More Refined Keyboard-to-Ribbon Transcriber	64
	VII.41 Modifications to Type 19 Teletype Set	65
	VII.42 Practical Operating Procedure	66
	VII.43 Checking Efficiency and Risk Level Attainable	67
	VII.44 Speed and Convenience of Operation	67
VII.5	A Workable Low-Risk Ribbon Interpreting and Index Scheme	67
	VII.51 General Capabilities	67
	VII.52 Coding and Marker System Used	69
	VII.53 Adaptability to the Type 19 Teletype	69
	VII.54 Effects on Packing, Density, Erasure, Reversability	69
	VII.55 Definition of "Correct Operation" of the System	70
	VII.56 Types of Faults Disclosed in Correct Operation	70
	VII.57 Types of Faults Resulting in System Malfunction	71
VII.6	Design and Construction of Ribbon Interpreter and Indexer	71
	VII.61 Pulse Separator, Word End Chain Counter: Chassis I	75

50
55
60
65
70
75
80
85
90
95
100
105
110
115
120
125
130
135
140
145
150
155
160
165
170
175
180
185
190
195
200

[The text in this section is extremely faint and illegible, appearing as a series of horizontal lines.]

TABLE OF CONTENTS (cont'd)

VII.62	Controls, Minus marker, Totals Counter, Early Circuit: Chassis II.	76
VII.63	Shifting Register and Associated Gates: Chassis III	76
VII.7	Low Risk Scheme for Printing from Magnetic Ribbon	76
VII.71	Adaptability to Type 19 Teletype	76
VII.72	Verification System and Risk	77
VII.73	Speed and Convenience	77
<u>VIII. BINARY ELEMENT EXPLORATION: TEST APPARATUS</u>		
VIII.1	Techniques: Development of Special Test Apparatus	78
VIII.2	Power Supplies	78
VIII.3	Oscilloscope Auxiliary Sweeps, Markers, Triggers	79
VIII.4	Oscilloscope Voltage Calibrators	79
VIII.5	Pulse Forming Circuits	80
VIII.6	Sliding Pulsers	80
VIII.7	Transmission Line Pulse Grouper	81
VIII.8	Vacuum-Tube Life and Fatigue Tester	82
<u>IX. BINARY ELEMENT PERFORMANCE STUDIES</u>		
IX.1	Eccles-Jordan Toggle Circuits: Criteria	84
IX.11	Symmetrical Pulsing	84
IX.12	Performance of 6J6	85
IX.13	The case for Triodes	86
IX.14	Screen Pulsing	87
IX.15	Performance of 50B5 Screen Pulsed	87
IX.16	Performance of the 6AK6	88
IX.2	Cathode Coupled Binary Circuit	88
IX.3	Thyratron Control Recovery Time	88
IX.4	Non-Linear Passive Coupling Elements	89
IX.41	Glow Tube Possibilities	89
IX.42	Crystal Rectifiers	90

IX.5	Asymmetrical Pulsing; Study of Transfer	90
IX.51	Memory During Transfer	90
IX.52	Transfer Order with Sign	91
IX.53	Transfer Cycle vs. Transfer Pulse	92
IX.54	Amplitude vs. Time Sensitivity	93
IX.6	6J6 Performance Asymmetrically Pulsed.	93

X. REGISTER COMPONENT STUDIES

X.1	Performance Criteria	95
X.2	6J6 Shifting Register with Gates and Condenser Memory	95
X.3	Brown-Rajchman Shift Scheme	95
X.4	Pulse Propagation Shift Schemes	96
X.5	Transfer Between "Locked" Elements	96
X.6	Transfer Between Coupled, Asymmetrically Pulsed 6J6's	97
X.7	Positive Shift and Transfer 6J6 Register	99

XI. IMMEDIATE PROSPECTUS

XI.1	Shifting Register	100
XI.2	Shifting Register and Accumulator	100
XI.3	Detailed Design of Input, Output and Outer Memory Organ	100
XI.4	Exploratory Study of Control Organ	100

I. REMARKS ON ORGANIZATION

I.1 OUTLINE OF OBJECTIVE

As indicated in the report of Burks, Goldstine and von Neumann (hereafter referred to as "Logical Design I" or L. D. I.) our objective is to realize an electronic computing instrument embodying four essential primary organs:

1. Input - Output
2. Arithmetic
3. Memory Storage
4. Control

These are to be combined to form a "general purpose" computing machine; that is, one capable of carrying out the four arithmetic operations in any desired sequence without the preparation of any special auxiliary programming device such as cards, tape, etc. Instead, the programming for both central and sub-routines is to be supplied by code concurrently with, and via the same channel, as, the input numerical data. The binary system is to be used, each "entry" being of 40 binary-place (about 12 decimal place) accuracy. It is hoped to be able to add such binary entries at a rate on the order of ten microseconds including carries, and to multiply and divide at something like one-tenth this rate. The memory organ is to consist of two parts: An inner ("immediately accessible") memory capable of storing a few thousand (probably 4000 entries of 40 binary digits) and of divulging any entry within twenty or thirty microseconds after receiving the cell index and order: and an outer memory of vastly greater capacity, serially accessible, and capable of loading or unloading the inner memory in perhaps five or ten seconds.

The entire device is to be fully automatic, easy to code and program and of maximum reliability throughout; it is to contain as many and as complete checking features as technically feasible, and is to use

as few vacuum tubes and be as compact as possible.

I.2 PROGRAM OF EXPERIMENTATION, DESIGN, CONSTRUCTION.

The development of such an instrument is certainly no small undertaking, it being originally estimated that about three years would be required before any machine would be forthcoming; and that during this period approximately ten persons would be engaged full time. The work of such a development may be divided into essentially four stages: Exploratory, experimental component design, operable design and finally, construction and fault-elimination. If such a program were rigidly followed, no significant computational results could be expected until the completion of the fourth and final stage, so that the utility and short-comings of the outfit as a computer could not be appraised and alterations incorporated until completion. In view of the unprecedented speed and flexibility of the proposed machine, it was early agreed desirable to be able to experiment computationally as soon as possible in the course of the development, so that the advantages and shortcomings of the design could be assessed and improvements of both theoretical and technical sorts evolved. Accordingly, instead of a finished instrument after three years of development, our present aim is to achieve a crude but, in its main parts, operable machine considerably earlier; this would be what is known as the "bread board and plate model" type, lacking, however, certain automatic features. This apparatus would then be evaluated in computational experiments while improvements are being developed and the design theory re-examined.

I.3 FACILITIES

Initially no equipment, space or technical personnel were available for the physical side of the project. On January 1, 1946, the first engineer, John C. Sims, joined the project and began the spade-work of procuring tools

THE HISTORY OF THE UNITED STATES OF AMERICA

The history of the United States of America is a story of growth and change. It begins with the first settlers who came to the shores of the continent, seeking a new life and a better future. These early pioneers, whether they were Native Americans or European explorers, laid the foundation for the nation that would follow.

As the years passed, the United States grew in size and power. It expanded its territory across the continent, from the Atlantic coast to the Rocky Mountains and beyond. This expansion was not without conflict, but it was also a time of great discovery and achievement. The United States became a land of opportunity, where people from all over the world came to seek their fortune and build a new life.

The American Revolution was a turning point in the nation's history. It was a time when the people of the United States declared their independence from Great Britain and established a new government based on the principles of liberty and justice for all. This revolution was a bold and courageous act, and it paved the way for the United States to become a major power in the world.

The United States has since continued to grow and change. It has faced many challenges, both at home and abroad, but it has always emerged stronger and more united. Today, the United States is a land of freedom and opportunity, where people from all backgrounds and cultures can live and thrive together. The history of the United States is a story of hope and dreams, and it is a story that continues to inspire and guide us today.

and equipment. Since it was clear that the input and output devices (as well as certain other components) would, of necessity, be electro-mechanical, a small shop (one lathe, one drill, 1 planer) was established in the boiler room of the Institute. In March, William S. Robinson, machinist, joined the group. Lumber was purchased, experimental benches and work tables constructed, and the initial steps toward procurement of an inventory of standard electrical components (tubes, resistors, test instruments, etc.) were undertaken through cooperation with U. S. Army Surplus groups. In April, another engineer James H. Pomerene, came to the Group from Hazeltine Laboratories and assumed the responsibility for procurement of electronic equipment, followed by Willis H. Ware in June. On June 1, Julian H. Bigelow, formerly with the Applied Mathematics Group, Columbia University, joined the Institute group as engineer in charge. Also in June, two engineers who had had considerable experience on the ENIAC joined the group: Robert F. Shaw and John H. Davis. At the same time Ralph J. Slutz came from Palmer Laboratories. By July a workable experimental room had been established in another part of the basement of the Institute, and an adequate supply of tools, parts and instruments had been assembled. It seems fair to state that toward the end of July, effective experimental work was in progress.

I.4 AID FROM COOPERATIVE OUTSIDE GROUPS.

Although adequate facilities and personnel were available for electronic component and circuit experimentation by August 1, it is clear that many important aspects of the development of a computing instrument as described in "Logical Design I" could not adequately be handled with these facilities. Accordingly, it had been planned from the beginning of the project to rely heavily upon aid from outside cooperative groups for the development of such

components as could not conveniently be handled with the facilities available at the Institute. In particular, entire reliance for the inner memory component was to be placed upon Radio Corporation of America Laboratories, and the "Selectron" tube is being developed currently by Jan Rajchman of RCA to fill this need. The possibilities of photographic techniques for outer memory are being investigated by A. W. Tyler, of Eastman Kodak. For input and output keyboard-coding equipment, it was anticipated that modified commercial apparatus such as teletype could be used; aid in the development of these modifications is expected from the group working under R. D. Huntoon at the Bureau of Standards. On other electronic assembly and production work, as well as on certain construction of mechanical components and machine work, reliance will be placed on outside sources.

I.5 PERSONNEL

At the date of writing, the technical group at the Institute consists of four engineers and five technicians, a draftsman and a part-time purchasing agent. Two engineers are expected to join the group within the next month, and this strength of personnel is expected to be adequate for the main part of the development period of the project.

I.6 DATES AND PROGRAM OF ACCOMPLISHMENT

At present the exploratory phase of the work is well advanced. In the course of 1947 it is expected that crude but workable units will have been completed representing in full complement all primary component organs; more particularly, 1) a serial-feed input and output component utilizing magnetized wire, on which capacities of less than 10^8 characters will ordinarily be required, but which will be capable of storing as much as about 10^{10} ; and of loading the inner memory within the prescribed 5 to 10 seconds; lacking

however, full checking features and the ability to reverse and seek a given place upon orders received from the machine; 2) keyboard coding facilities capable of placing signals upon the wire, but lacking complete checking features; 3) arithmetic organs consisting of two registers capable of shifting either right or left and one accumulator also capable of shifting right or left as well as "carrying", all operable at prescribed speeds; 4) a workable, though not completely automatic control organ; 5) a bank of inner memory tubes.

Within about a year from the above date it is expected that it will have been possible to add the missing features, giving full flexibility and rather complete checking to these components, and to have produced a workable and fairly complete machine.

II. GENERAL DISCUSSION OF COMPUTER

II.1 DEFINITIONS: Organs, Components, Elements.

Before entering upon a general discussion of the proposed computing instrument it will be convenient to establish a vocabulary of several generic terms, by the usual process of definition:

"Organs" are portions or sub-assemblies of the machine which constitute the means of accomplishing some inclusive operation or function; as "arithmetic organ".

"Components" are portions or sub-assemblies of organs, and carry out all of an essential step in the function of the organ; as "register component".

"Elements" are fundamental individual units cooperating to form a component; in general, not structural items such as tubes, resistors, etc. for which the term "part" is reserved, but rather purely local combinations of parts comprising a local "cell" or "stage"; as "binary element".

II.2 BLOCK DIAGRAM

Referring to the Block Diagram (Figure 1), organs of the instrument are enclosed in dashed-line boxes annotated in the upper right corner; they may be collected into four classes:

- T - Terminal organs (T_1 and T_2)
- M - memory organs (M_1 , M_{2A} and M_{2B})
- A - Arithmetic organ
- C - Control organ.

THE HISTORY OF THE UNITED STATES

CHAPTER I. THE DISCOVERY OF AMERICA.

The discovery of America by Christopher Columbus in 1492 is one of the most important events in the history of the world. It opened up a new world of opportunity and led to the development of a new civilization.

The discovery of America was the result of a long and arduous journey.

Columbus set sail on August 3, 1492, with three ships and a crew of 90 men.

After a long and difficult voyage, he discovered the island of San Salvador on October 12, 1492.

The discovery of America was a great triumph for Columbus.

It was the first time that a European had reached the Americas.

The discovery of America led to the development of a new civilization.

The Spanish conquistadors who followed Columbus discovered a rich and fertile land with a population of millions of people.

The discovery of America was a great triumph for the Spanish crown.

CHAPTER II. THE EARLY YEARS OF THE COLONIES.

The early years of the colonies were marked by a struggle for survival. The colonists had to build their own homes and farms, and they had to defend themselves against the Indians.

The first colony was established in 1607 at Jamestown.

The second colony was established in 1620 at Plymouth.

The third colony was established in 1630 at Boston.

The fourth colony was established in 1633 at Maryland.

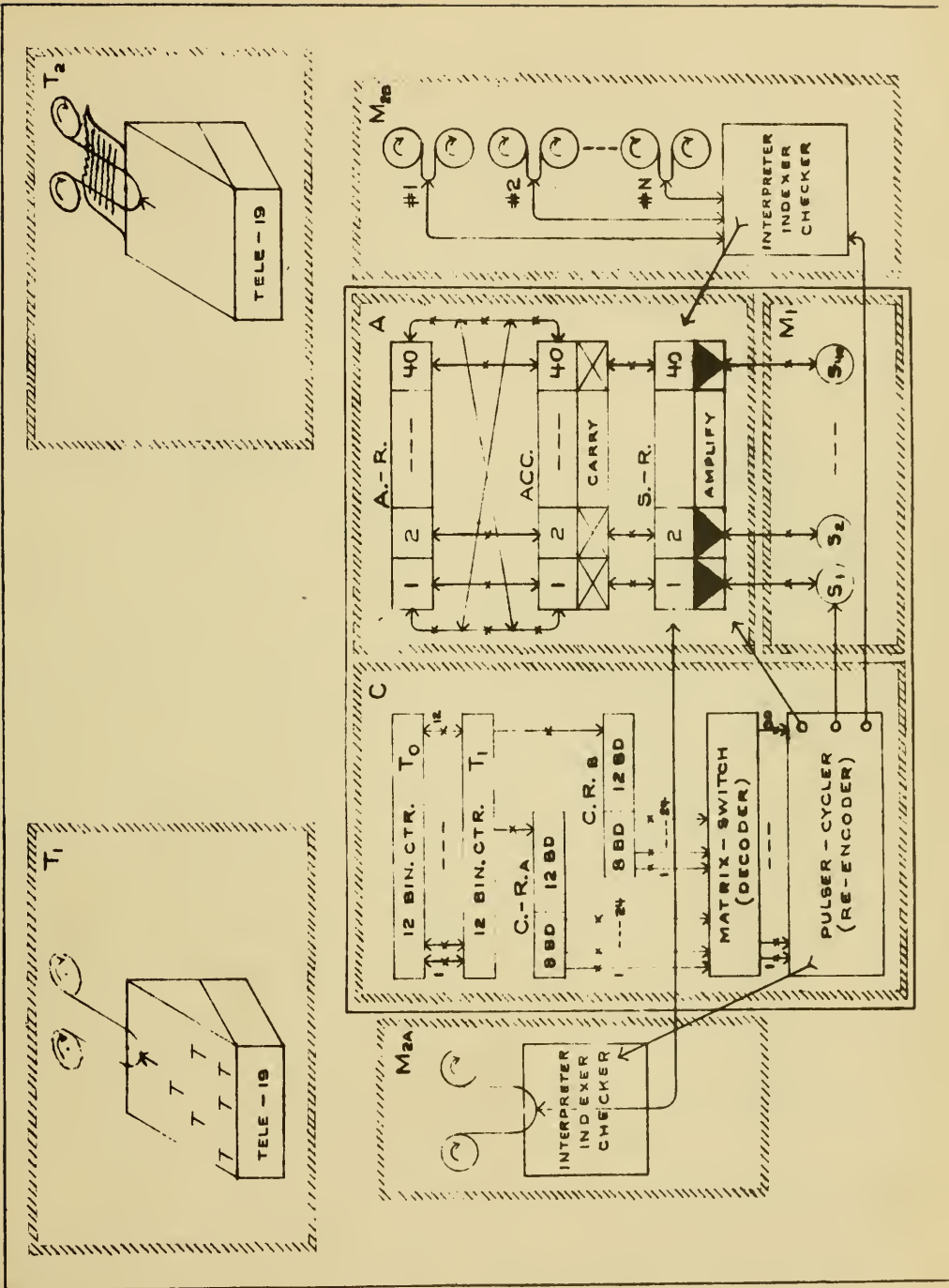

Figure 1
I.A.S. Electronic Computing Instrument
Block Diagram

The terminal organ appears twice in the diagram, as input (T_1) and output (T_2); while the memory organ appears at three places -- inner memory (M_1), outer memory associated with input (M_{2A}) and outer memory associated with output (M_{2B}). Within each dashed organ-box components are indicated by solid line boxes (generally bearing inscriptions) frequently subdivided to indicate "stages" or "elements", as defined in II.1.

II.3 ORGANS AND FUNCTIONS

II.31 Terminal (Input-Output).

The terminal organs permit transcription and coding of a problem from printed manuscript to pulses on magnetic ribbon. The apparatus presently contemplated for this purpose is modified Type 19 Teletype keyboard-transmitting and receiving equipment. The operation is essentially as follows: One (or more, if independent checking is desired) teletype operator reads from the manuscript a prepared problem consisting of data entries and orders as to their manipulation. The data and orders will be grouped into 40 binary digit words, each representing one number or two orders. These words will be read from manuscript and typed on a keyboard in terms of 16 symbols; perhaps 0-9 plus a-f. Each symbol will correspond to a tetrad (4-group) of binary digits. With this arrangement, data may be transcribed in either true binary or coded decimal form; in the first case placing on the magnetic ribbon 40 binary characters consisting of 10 tetrads selected on the keyboard, (ordinarily using the first binary character to indicate + or - sign) and in the second case placing on the magnetic ribbon an ten-tetrad decimal number, of which the first tetrad may represent sign and the other decimal digits.

The input orders will be half a word, similarly coded as 20 binary or five-tetrad decimal characters. These orders are essentially the 21 listed in Table I of L. D. I. (Page 56) although additions and modifications of that

scheme are likely. Concerning the numbers, their treatment in the decimal and binary systems and conversion procedures, see a subsequent report entitled, "Planning and Coding of Problems for an Electronic Computing Instrument", by von Neumann and Goldstine; in particular Chapter 9. In regard to coding, handling orders, combining orders, etc., see Chapters 7 and 11 of that report.

A detailed procedure (described in VII.3 and VII.4) will be followed in this operation whereby overall checking is accomplished. The result of this operation is the problem coded magnetically on wire or ribbon at T_1 ; or T_2 a corresponding "end-result" magnetic record is run through one (or more units for checking) of the same Type 19 apparatus and printed out in readable form. Notice that while this human-keyboard-typewriter operation is essentially slow and painstaking, it is entirely independent of the machine proper, and any number of coding crews intimately or remotely located relative to the machine may be setting up problems while the machine is solving those coded earlier.

II.32 Memory (Inner and Outer).

The memory organs are of two sorts: The inner, electronic memory, M_1 (to consist of Selectron tubes), and the outer magnetic ribbon memory, M_{2A} and M_{2B} . This division of memory is not required by any logical reason but is necessitated by the technological impracticability (to date) of combining the speed and accessibility of M_1 with the enormous capacity of the slower, serially accessible M_2 . Outer memory M_{2A} consists of magnetic ribbon, which may be serially transferred into M_1 in doses up to 4,000 entries, upon orders from the operator; or in the fully automatic machine upon orders from the control, "C". M_{2B} consists of a bank of magnetic ribbon drives identical to M_{2A} except that they will initially be blank (or may contain tabulated functions or programs) and will receive output data for printing, or re-insertion as new

1. The first part of the document discusses the importance of maintaining accurate records of all transactions and activities. It emphasizes that this is essential for ensuring transparency and accountability in the organization's operations.

2. The second part of the document outlines the various methods and techniques used to collect and analyze data. It highlights the need for a systematic approach to data collection and the importance of using reliable sources of information.

3. The third part of the document describes the process of interpreting the data and drawing conclusions from it. It stresses the importance of being objective and unbiased in the analysis and of considering all relevant factors.

4. The fourth part of the document discusses the role of the organization in promoting and supporting research and development. It notes that this is a key responsibility of the organization and that it should be given the highest priority.

5. The fifth part of the document concludes by summarizing the main points of the document and emphasizing the need for continued effort and commitment to the goals of the organization.

data; actually M_{2A} and M_{2B} will appear as a single bank of magnetic ribbon feeds, any one of which is capable of receiving or implanting data upon switching; (manual in the primitive, automatic in the final machine) the difference in function being merely conceptual. Associated with the ribbon feed components of M_{2A} and M_{2B} is an interpreting and indexing component having the ability to read and keep account of the 40 digit data-and-order entries on the wire; of checking these for errors against a system of marker pulses placed upon the wire, and of disclosing various reading faults by error signals (see VII.5). The inner memory M_1 receives data and orders in batches from M_{2A} , via the register component S.R. to which it re-issues arithmetic data and orders upon command arriving from C via the pulser-cycler component; and finally M_1 discharges its information into M_{2B} , requests more from M_{2A} .

II.33 Arithmetic organ A.

The organ A accomplishes all of the arithmetic processes (+, -, \div , \times) upon command of the control C; it consists of two essential components:- the arithmetic register "A-R", and the arithmetic accumulator "Acc."; also it includes the selectron register "S-R", not essential (though convenient) to the arithmetic function, but necessitated by practical considerations (III.22). The register component A-R consists of a bank of 40 binary cells capable of retaining or clearing a 40 binary digit entry; it is therefore basically a memory-bank. However, it is not classed as a memory component because its contribution to the total memory of the instrument is negligible; its valuable properties are that not only is it able to remember indefinitely, then "forget" upon demand, but also it can shift its entire contents right or left, expelling digits at either end; and further it can transfer the entries (which it contains) in parallel (cell-wise) to other components of the arithmetic organ (viz. to Acc.). The Accumulator component is like the Register component and has all

of its properties, plus the additional property that it can add any incident 40 binary digit entry to whatever it already contains, effecting the necessary carries (L.D.I. page 22). These component properties are suggested diagrammatically in Fig. 1; shifts by "and around" arrows, and cell-wise transfers by parallel arrows. The remaining component, S-R has all the properties of A-R plus the additional property of very high sensitivity to transfers from the bank of Selectron tubes $S_1 - S_{40}$ constituting M_1 . This high sensitivity can be thought of as accomplished by a bank of buffer amplifiers between $S_1 - S_{40}$ and S-R but actually other techniques of sensitising S-R not requiring additional amplifying tubes are under consideration and may prove suitable (III.12)

II.34 Control Organ C.

This organ is schematically the most complicated, since it comprises many types of simple components and elements rather than a few basic components as in organs previously discussed. In general, C receives 40-character-orders from M_1 via S-R and stores them in two 20 digit registers C- R_A and C- R_B . For economy, each such 40 binary digit (B.D.) entry consists of two orders coded in 20 B.D. each, so that C- R_A and C- R_B each receive an order. Every such 20 B.D. order consists of 8 B.D. conveying the nature of the order and 12 B.D. conveying the index number. These orders are conditionally passed into the matrix switch (de-coder) whence they issue as commands to the various organs and components of the machine. Further essential components of the Control are: - at least two binary counters of capacity 12 B.D. to store present (t_0) and next (t_1) order numbers; also numerous gates and interlocks not detailed here but to be discussed in a later report (see XI.5). It may be remarked that the components of the control are in general similar to those used in A and elsewhere in the machine, but rather of less multiplicity and less exacting

speed requirements. The pulser-cycler component of the control presents somewhat of a special problem since it is called upon to enforce - at relatively high energy level - the commands of C upon various multiple stage components in A and elsewhere. In reality, the control here diagrammed as an organ collected within the box "C" will probably be distributed throughout much of the machine according to practical engineering convenience.

II.4 COMPONENTS

The components, comprising subassemblies of organs, are of three sorts.

- 1) Memory-Element banks or chains, having particular differentiating features.
- 2) Gate systems or switching cascades whereby various circuits are permitted to pass information to the exclusion of others.
- 3) Pulsers or power amplifiers capable of reproducing signals at increased energy level.

Included in the first class are all registers such as A-R, S-R, C-R_A and C-R_B; also the accumulator, various binary and ring counters used for indexing and preserving sequence, etc. Essential to all of these is the property of time-stable storage, so that upon interrupting the operation of the machine at any stage all data and orders in process are isolated in these components. The differentiating features between components of this class usually consist of accessory gates and amplifiers; for example, the 'carry circuit' differentiating Acc. from A-R is a gate system, while amplifiers distinguish S-R from A-R. Notice that the essential role of memory in this class of components necessitates their receiving two distinct orders: "hold" and "clear".

The second class of components, the gates or switching cascades are essentially conditional transducers; they have no memory and in fact the nearer

their action approaches being instantaneous, the more efficient they become. Individual switches or gates joining two channels upon instigation at a third, are properly called elements; but such elements may be combined into relatively complex units, when the term component is justified. Examples of such components are the matrix-coder and de-coder, both located in the control organ. Another example (not shown but which might conceivably be included), would be a decimal-to-binary converting matrix component.

The third class of components include pulsers and power amplifiers; the latter have absolutely no memory in the ideal design, but merely re-issue a signal at higher energy level with minimum delay; the amplitude-time characteristic of this signal may, however, deliberately be modified. Pulsers are like amplifiers except that they execute a certain cyclic time sequence upon the arrival of each instigating signal; the nature of the output being independent of the input. The fact that the output does involve a cycling time implies the deliberate design of a brief, automatically clearing memory in this component; frequently, however, pulsers are used to drive elements of exceedingly rapid apprehension so that the aim of design is to minimize the pulse duration, and in fact this is frequently in practice determined by the residual parasitic time-constants of the pulser circuit.

II.5 ELEMENTS

Most of the essential elements or "Cells" in the machine are of a binary, or "on-off" nature. Those whose state is determined by their history and are time-stable are memory elements. Elements of which the state is determined essentially by the existing amplitude of a voltage or signal are called "gates" or non-linear transfer elements. The three-element vacuum tube is a convenient means of realizing both memory cells (as in Eccles-Jordan

circuits) and gate cells (taking advantage of grid or plate cut-off characteristic). Other elements such as crystal rectifiers, relays, etc. may be used (cf. IX.1). In addition the vacuum tube has the property of energy amplification at exceedingly high response speed, so that it lends itself to amplifier and pulser use.

II.6 PHILOSOPHY OF CHOICE

In the design of the subject computing instrument certain guiding principles have been formulated through combination of logic and prior experience (see L. D. I.). However, many questions bearing on the physical realization of this design remain unclarified, and for just this reason the machine is to be progressively and experimentally developed rather than designed and built to specification. Insufficient data exists relative to many important questions of design, so that it is clear that early decisions will fall short of being optimum, though perhaps well advanced for the field. This is particularly true in regard to the statistics of errors and failures, on which there are practically no data fit for guidance in design.

II.61 Criteria of Speed

Consider various criteria of good performance; in particular, the criteria of speed. It has been stated that basic transfer operations are desired at a microsecond rate; for what classes of elements does this represent "pushing to the limit" with consequent approach to the threshold of failure? Certainly, for a given sample component one can measure this experimentally, but this is not very significant; the probability of failure depends essentially on the variance among elements, operation conditions, supply voltages, input pulses, etc. Further, the probabilities of failure in which one is interested are extremely low, making an artificial experiment difficult.

One may attempt to increase speed of operation by a number of means, as by:

- 1) The use of elements having extremely rapid reaction times.
- 2) Use of many "built-in" sub-routines particularly optimized for brevity.
- 3) Paralleling operations and duplicating components.
- 4) Combining and telescoping the operation of various components functions, eliminating intermediate stages of storage, amplification, etc.

II.62 Criteria of Certainty.

On the other hand it may be desired to maximize the certainty of operation of the machine; clearly this may be done in various ways, such as by:

- 1) Operating elements at conservative (sub-normal) ratings.
- 2) Duplicating operations through use of parallel or checking channels, or by repetition in a given channel.
- 3) Isolating and verifying the operation of various components by means of checking circuits, etc. before forwarding results to the next in succession, etc.

II.63 Interdependence, Simplicity.

Under certain hypotheses, it would appear that increasing speed by any means results in a decrease in certainty, and vice-versa. If this were true and if means could be found for exploring the implied simple relationship, the problem of design would be enormously simplified, and it would be known whether to build a parallel-acting machine having many rather slow, reliable components, or to build a high speed, relatively inaccurate machine with

frequent checking and comparing features. Certainly much speed can be used to compensate for some inaccuracy, whereas high reliability can, by sheer duplication, be forced to produce high speed.

However, such data, experience and intuition as are presently available suggest that this simple relationship between speed and certainty does not underlie the performance of vacuum tube elements at megacycle rates, and in fact that increasing speed may actually increase certainty rather than the reverse.

The fundamental question is, what are faults dependent upon? Consider first two classes of element failures.

- A) Failures to transfer; that is, malfunctions associated with the execution of a stop in the computing process.
- B) Failures of an element not brought about by attempting to operate that element, by some cause independent of that act.

The probability of type A failures certainly depends on the number of transfers a given data entry undergoes as it is routed through the instrument. The probability of type B failures depends only upon the elapsed time during which a given data entry lies within the element in question. Either type failure may be said to be due to a "weakened" element.

Furthermore, a very pertinent question is: Does the "weakening" of an element depend primarily upon the number of times it is operated, or primarily upon accident or age?

The design implications of these questions are quite clear. Minimization of A implies utmost simplicity in design and programming; B indicates reduction in process time. If elements are not weakened by use but by other effects among which is age, then they should be used at as high a rate as

possible. Further, most classes of elements (containing tubes) suffer accidental failures in proportion to their population, which implies use of fewer elements operated more frequently. Finally, intermittent errors are most embarrassing and difficult to detect when the intermittency corresponds roughly to the operating rate; this suggests that high operating rates will make broader classes of such errors appear systematic, and likely to attract attention.

It therefore appears likely that optimum reliability per calculation may occur at relatively high speeds; that is, at some rate below that at which the capabilities of the tube-element are critically taxed but yet high enough to afford an efficient duty cycle for each element, with minimum circuit redundancy.

II.64 Energy and compactness

The question frequently arises as to the reliability of a scheme realized by relatively large elements, operating at a fairly high energy level, compared to the use of miniature elements operating at very low energy levels. The answer can rarely be given on a factual basis, but a few remarks may be of interest. Consider the choice of register elements built with miniature tubes, such as the 6J6, compared to larger power-amplifier tubes. Reliability of both mechanical structure and electrical characteristics should be considered; on the mechanical side little data exists, but what there is suggests that the 6J6 is at least equal to most larger tubes in ruggedness. Electrically the 6J6 requires less energy to operate and to activate, and has less output available. However, the ratios of output to input are very high, and the compactness of the miniature type promotes circuiting which is compact and retains its performance at megacycle rates: The choice of 6J6

(or the similar 2C51) therefore appears rational, and indeed if the tube were scaled down to a quarter its size it would probably be still more suitable. (See IX.12)

II.7 Beliefs with undefined side conditions

Many points in the progress of realization of the subject computer must be decided on the basis of beliefs based on past experience, which for one reason or another cannot here be presented as conclusive scientific arguments. Attempts will later be made to clarify the conditions under which these beliefs are valid, but for the present they are merely outlined for criticism and comment.

II.71 Amplitude vs. Time Sensitivity

All electrical circuits are inescapably both amplitude and time sensitive; if there is no amplitude change, no information is transferred; if an amplitude change occurs for zero time, no information is transferred. While it is meaningless to discuss the merits of amplitude-sensitive circuits as compared to time-sensitive circuits, it is very significant to consider whether it is best to accentuate the property of "transferring" when a certain amplitude value is reached, and never below that value; it being required that the value be maintained for at least a certain brief time. This is essentially how a non-linear coupling element (a Flip-Flop, or biased rectifier) operates and may be contrasted with a time-constant (resistance-capacitance) coupled circuit. It is believed that the amplitude-sensitive coupling, capable of operating at all dwell durations from DC to the minimum reaction time of the transfer elements, has many advantages. In particular, its acting speed and recovery time is limited only to the minimum reaction time of the elements involved in the transfer, so that rates may be pushed up to this natural limit,

Furthermore, it has a "dead" or safety zone, and its operation is independent of pulse shape. On the other hand, the linear (R-C) coupling depends on both pulse duration and amplitude; that is, upon pulse shape; and is in fact an attempt to discriminate by linear filtering technique between (1) the time of response of the transfer elements, (2) the time characteristics of the pulse, and (3) the repetition time of the pulses.

II.72 Information transfer as a function of interval.

Consider the problem of transferring binary information between two elements at an ever-increasing rate; this corresponds to transfers during intervals of shorter and shorter durations. The transfer signal consists of an amplitude excursion of ever-increasing dwell; the "area" or "steady state" properties are vanishing and only the "jump" remains, with the implication that the more closely the coupling elements resemble time-constant-less non-linear operations, the further this process can be pursued. These points will be made more precise in later reports.

II.73 Pulsers, Clocks, Closed Cyclers.

In principle, transfer operations between either linearly (R-C) or non-linearly (biased rectifier) coupled circuits can be effected by pulsers of which the signal duration is longer than the element reaction time. They can also be operated by "clocks" holding open gate tubes during intervals bracketing the action time. However, either of these schemes may fail to effect transfer in the case of an insensitive element, without disclosing the failure. One method of avoiding this is to use a "closed cycler" operating on feedback from the results of the transfer operation, as follows: Upon arrival of the order to transfer at the cycler, this device immediately produces a rapidly increasing voltage of steep wave front; this voltage

continues to mount until a return report arrives at the cyclor that the transfer order is completed, upon which the cyclor returns rapidly to zero. Here the completion of the operation terminates the cycle, otherwise the continued increase in amplitude operates a "failure" signal.

II.74 Checking Processes

The close-cyclor is an example of a transfer-checking device operating on feedback. In principle, all such transfer-checking schemes involve the use of additional elements to remember what the transfer should be and signal its completion. In the case of the Selectron transfer, this implies duplication of each Selectron which appears infeasible. However, in case of register-transfers it is possible to devise schemes taking advantage of the observability of the elements before, during and after the transfer process; and of the memory of the transferring element. The net result of such schemes may be an actual increase in the total number of machine failures due to the presence of additional parts and operations, but they may have the effect of disclosing all transfer errors. Further attention is given these points in Sec. VII.2 - VII.23.

III. REMARKS ON THE REALIZATION OF LARGE MEMORY CAPACITY

III.1 DISCUSSION OF PERFORMANCE CRITERIA

The most basic technological problem in the realization of the computing instrument is clearly the problem of large memory capacity. Considerable thought has been given this problem both by our group and others, no wholly satisfactory answer having materialized. It may be of passing interest to indicate the chief performance criteria and qualifications by which such a memory would be judged.

III.11 Information Storage per Unit Volume

This is the number of binary digits per cubic inch stored in the memory. Any device making possible about a million binary digits per cubic inch would certainly fill the need beautifully; in fact one tenth this density would suffice, since contained in a cabinet 8' x 8' x 1' would be about 10^{10} binary digits.

III.12 Inscription Speed Range

It would be desirable that this memory be capable of receiving binary digits at any speed no matter how low, and at high speeds up to perhaps 40 binary digits per microsecond: although a top speed of 1/100 this figure would be acceptable. (This goal is far in excess of that of M_2 as proposed in Section VI.1, which is capable of about one 40 binary digit word per thousand microseconds.)

III.13 Reproduction Speed Range.

The memory should be capable of supplying information to a teletype at perhaps 40 binary digits per second, and of transferring into various electrical components at the same maximum speeds as inscription (III.12).

III.14 Accessibility

This is an extremely important attribute for a memory to possess, and implies that the entire memory be anywhere immediately inscribable and reproducible upon demand. It is this ability which makes the Selectron memory (M_1) desirable and not replaceable without some sacrifice by the serially accessible magnetic ribbon memory (M_2). However, by subdivision, a serial memory may be made to approximate an immediately accessible memory. (See III.34)

III.15 Verifiability

This implies that it should be possible to read the memory without clearing it, so that checking systems can be developed. It is a very desirable property of any memory in which failure of type A or B (II.63) may occur, (See Sec. VII.2 - VII.23)

III. 16 Erasability

This is an important attribute of a satisfactory memory, particularly where iterative routines involving partial substitutions are to occur. Both magnetic ribbon and Selectron memories have this property; photographic film does not.

III.17 Permanence

Eventually it is expected that a library of calculations, tabulated functions, procedures, etc. will have been accumulated by use of the machine; it is desirable that these be on some permanent record having a life of months or years. Magnetic wire seems to fill this need well, and any otherwise satisfactory memory could be unloaded onto wire to fill this need.

III.18 Durability

The memory should be capable of many millions of operations; or should be easily and quickly reproduced, in case of wear or deterioration.

III.19 Convenience and Economy

Certain schemes for realizing large storage capacity require processing between the inscription and reproduction operations; chief among these are photographic techniques. This is a considerable disadvantage, since the memory cannot then be erased nor can it be immediately re-read as required in many iterative techniques. Further, intervening processes of chemical variety are certain to prove a great inconvenience in the procedure of operating the machine. It would seem that the only feasible sort of non-erasable memory would be one immediately reproducible and on a medium cheap enough to be consumed and discarded in large quantities, so that the operation of reading and re-writing can replace erasure. Even then, the quantity of medium consumed in most lengthy problems would render the accessibility (cf. III.14) of the memory unacceptably slow.

III.2 MEDIA AND ENERGY STORAGE

Broadly speaking, any physical medium is potentially suitable for memory if it can be quickly and locally modified in a detectable way, and can thereafter be scanned. The local modification can be of a physical sort, as in the case of embossing a plastic, or in the nature of energy storage such as local thermal, electromagnetic or electrostatic charge. Various schemes were considered; for example, mechanically embossing wax cylinders, as in a Dictaphone, is a possibility. Such rolls are approximately ten inches circumference and six inches long; they could be embossed at about 100 digits to the inch at perhaps a five kilocycle repetition rate. If the tracking pitch were .010 inch this would produce a capacity of about half a million binary digits in each roll, serially scannable and immediately reproducible. The plastic nature of the wax might make erasure possible, and the cost of the medium is certainly low since by facing off the surface, each cylinder may be

re-used about a hundred times. However, several disadvantages remain: The embossed cylinder cannot be re-read many times without deterioration, and also the material is sensitive to accidental impressions, and (it is thought) likely to contain a statistically significant number of local mechanical defects producing false signals.

Also considered were schemes involving local energy storage on areas of some material, such as local charge on sheets of dielectric; local magnetization of surface areas; local temperature on chalk or other suitable surfaces, etc. Such schemes become feasible if suitable inscribing and scanning means can be developed. Electron streams can be used to charge, read and revive capacitative systems; this is essentially the technique of the Selectron and has the advantage of high-speed non-serial scan without use of moving parts. Similarly, electron streams could be used to detect local magnetic charge on surfaces, but are not suitable for inscribing, which requires heavy currents and implies electromagnetic devices. The combination of electronic detection with requirements as to vacuum, plus the electromagnetic recording requirement does not suggest any practical combination of these two; so that the only alternative is both recording and detecting by (moving) electromagnetic means; this is essentially what is used in M_2 to be discussed in detail below. Regarding the possibilities of thermal storage, no careful studies have been made; the suggestion results merely from the fact that heat may be deposited and detected by essentially optical means. Techniques of this variety may also be developed using fluorescence; this avenue is being explored by Eastman Kodak Company.

If schemes for developing non-erasable memory are to be given serious consideration it would seem worthwhile to investigate less elegant media than

photographic film. That is, photographic film is capable of all tones of light sensitivity from black to transparent; this is unnecessary if binary digits are to be recorded, and simpler "binary" chemistry could be used. For example, enough photo or electrical energy will turn white paper black by charring; a more practical example is ordinary radio-facsimile paper which changes from white to black by passage of a slight electric current. Conceivably something of this sort could be made fast enough and cheap enough to be reproduced and discarded rather than erased; however, no efforts have been made to explore this possibility.

III.21 Energy Level; Fundamental Role of Non-Linearity

For many practical reasons the most desirable memory medium would be one having two stable states at low energy level; this would lend itself to recording without excessive power amplification, and to reading with minimum risk of indecision due to the occurrence of borderline values. Experimentally, it may be observed that the existence of two stable states in a given medium is usually evidenced by non-linearity in the susceptibility of the medium to recording stimulus; media evidencing such non-linearity being often stable for long periods of time, while those not evidencing non-linearity often tend to one or the other "normal" state. This is particularly true of magnetic media.

III.22 Memory transfer; Amplification

In addition to the ability to "hold" and "clear" all memories must be able to transfer and receive information. Consider the problem of transferring from one memory cell to another; clearly this can be accomplished only with ^oless of energy, and some means of amplification must exist. Such amplification may actually be a buffer stage between cells, or it may be accomplished by de-stabilizing the recipient cell relative to the transmitting cell. This last technique has the advantage that it can often be done by a single device to

a whole bank of cells which are to be simultaneously transferred, so that a multiplicity of individual amplifiers may be avoided (see X.5 and X.6). This technique can nearly always be made effective if the medium is sufficiently non-linear; never if it is strictly linear.

III.23 Sensitivity Ratio Criteria

The time-stability of an energy-storing medium could therefore be expressed as the ratio of the energy necessary to erase a digit to that necessary to record the digit; and this ratio may, of course, fall off with time. These values are measured at the same terminals; in the case of elements combining two stable states in each cell with amplification in that cell there are clearly two such ratios, one at the input and one at the output end. In such a case the ratio of input energy to the output energy at any time gives something in the nature of a transfer sensitivity.

III.3 CELLULAR AND CONTINUOUS MEDIA

Certain technical points connected with the realization of large memory capacity do not depend on the particular medium used, but are rather more fundamental. In attempting to realize large capacity the urge is to avoid fabricating individual cells having individual connections and instead to use mass-produced cellular or even continuous media having cells defined by the recording process. This raises problems of scanning and of registration.

III.31 Problem of Scanning

All methods of seeking information located in a medium appear reducible to two; switching and traversing or "scanning"; occasionally combinations of these are used. Switching implies connector leads corresponding to each cell; scanning implies hunting by relative motion of a ray or some physical device.

In order that a switching system have capacity enough to make possible the identification of individual cells in a memory of 10^{10} , without involving an unmanageable number of leads, it is essential that the combinational possibilities of the leads be used. If this be done, memory capacity can grow factorially relative to the number of connectors, and there is some hope that the switching problem could be handled.

The technique of scanning implies switching by relative motion of some sort; about the only non-mechanical way of doing this is to use deflected electron beams either directly on the geometry of the medium, which is to say as an electronic switch; or the electronic beam may be used to produce fluorescence, affording an optical scanner. Either of these two schemes can be made extremely rapid compared to methods involving the motion of structural parts. Light may be used to some advantage to magnify mechanical motion; as by rotating mirrors or prisms; the oil damped Duddel galvanometer, for example, can traverse ten inches with a small spot of light in about one tenth millisecond and is reproducible in deflection to about 1/2 percent.

III.32 Problem of Registration

Associated with the means for relative scanning motion must be some system of registration, or of identifying cell areas in the medium. This may conceivably be accomplished more simply than by the construction of sets of leads together with a switch; for example, it may be realized by a single cartesian grill over which the scanner travels, counting the bars to locate cells. In this case the identifying wires could be replaced by a grill and a single lead wire, together with a counter. If a further assumption can be made - that the deflection of the scanning ray is reproducible (not necessarily linear), then a further simplification can be made; the grill can be replaced

by remotely situated reference scales, such as stepped voltage dividers, one corresponding to each coordinate of the medium.

III.33 Three-Dimensional Continuous Media

Although the efficiency of a storing medium is properly expressed volumetrically, no essentially three-dimensional practical storage medium has been disclosed. The capacity of various filaments and sheets can be expressed in one or two coordinates, as next described.

III.34 Two-Dimensional Continuous Media

Among those considered were paper sheets coated with powdered magnetic material, formed into cylinders and scanned by rotation; spiral tracks of magnetic wire wound on cylinders and scanned by rotation; optically sensitive sheets scanned by light spots from prisms or mirrors, or electron beam spots, etc. A representative scheme of this sort, and one which may require further investigation is the following: Consider a cylinder about 3 inches in diameter and 10 inches long; its circumference is 10 inches and if a wire capable of holding 100 binary digits to the linear inch were wound in a groove of .010 pitch this would give a total memory capacity of 10^6 binary digits. If this were rotated at 6000 RPM (it certainly could be rotated at many times this speed) each turn would require 10 milliseconds, which would be the longest waiting time for any digit. The average wait would be 5 milliseconds and by increasing speed and/or using several sensing stations this could certainly be reduced to 1 millisecond. The digit rate would be about 10^5 per second,

III.35 One-Dimensional Continuous Media

Under this heading come storage-delay devices such as transmission lines, acoustic tanks, etc., also various magnetic ribbons, perforated tapes, films, etc. Of these, the magnetic ribbons appear to us to offer far greater

potentialities than any of the others toward realization of large digit capacity, and in addition are simple, erasable, immediately reproducible, free from temperature coefficients, chemical processes, etc. Accordingly, our main experimental effort was in this direction, and in what follows all references to serially scanned storage media imply this type.

III.4 VARIOUS "MAGNETIC RIBBONS"

Since about five years before the war, and particularly during the last few years, various magnetic ribbons for speech and music recording have been developed. Among these are wires of ferrous and magnetic alloy types, flat tapes formed by rolling such wires, evaporated metallic layers on plastic threads and ribbons, and paper and plastic tapes coated with powdered ferrous alloys, of colloidal grain-size. Various claims are advanced for these ribbons, primarily centered on their performance in reproducing speech and music. Essential to such performance is the property of amplitude linearity, or at least something in the nature of amplitude proportionality, and much effort and ingenuity has been applied toward accentuating this property.

It is clear that for the recording of binary information this property is not essential; in fact is very undesirable. The ideal observed response curve for binary recording would be (as already indicated) sharply S-shaped having little or no response over a certain region, then a very short transition to a "saturated" or completely activated state. Certain of the magnetic ribbons do in fact have this sort of response, of which full advantage will be taken in the final design of the memory component.

III.41 Performance Criteria; Head Design, orientation, amplification

The "best" magnetic recording ribbon for M_2 will be determined by a combination of properties rather than by any single virtue, including those

listed in Section III (III.1 - III.19). It is very difficult experimentally to separate the performance of the ribbon in these respects from that of the recording head, and most of our measurements represent their joint performance. It is quite possible that the rank of the ribbon samples reported in our tests would be affected by a change in head design, but it is unlikely that a radically different ranking would result.

There is also the question of head orientation relative to the medium; various experimenters (particularly the flat tape advocates) recommended transverse or crosswise magnetic orientation as opposed to the longitudinal arrangement used in our tests. We have no knowledge as to the merits of these schemes for binary recording, and intend to investigate them at some later date.

Again there is the question of reproduced signal voltage; this is certainly greatly affected by head design, so that the required amplification will be affected by this factor. It is believed that considerable improvement can be made; by merely re-winding the pick-up coil; a gain of five to ten-fold may easily be possible.

III.42 Density of Information

One of the most important figures of merit is the maximum linear density with which information can be packed on the ribbon or wire without (1) interference by adjacent pulses in such a way that the signal level of a given pulse is appreciably affected by the presence and polarity of its neighbors, and (2) reducing the signal level to the vicinity of the noise level. This figure, together with the cross-sectional dimensions of the sample, determine its volumetric storage capacity.

III.43 Positive and Negative Sequences; Signal Integration

As indicated elsewhere in this report (VII.2 - VII.28) it is desirable for checking and other reasons to avoid using the absence of signal as

representing anything except failure; in particular, it is desirable to represent both 1 and 0 by voltages, of opposite sign. Hence the magnetic medium will be inscribed with both positive-sequence and negative-sequence magnetic pulses, and when reproduced by motion relative to an electro-magnetic pickup, this by differentiation will produce pairs of voltage pulses, + - for one recording polarity and - + for the opposite. These voltage outputs could be distinguished by any (or a combination) of four reading methods:

- 1) By rectifying and excluding either the first or second pulse;
- 2) By a rectifying and adding switch whereby the second pulse is changed in sign and added to the first (or vice versa);
- 3) By differentiation; relying upon the observed fact that the rate of voltage change is greater between pairs of voltage pulses than the initial or final slope;
- 4) By simply integrating with respect to time, so that the summation of area of the first pulse is cancelled by the summation of the second.

Scheme 3) requires further investigation to determine whether it may increase the usable pulse density on the medium; scheme 4) is the simplest and since it appears to have a favorable effect upon the signal-to-noise ratio, will probably be adopted.

III.44 Inscription Speed Range

It is essential that the magnetic ribbon be capable of inscription at relatively high speeds, so that the Selectron memory (M_1) can be emptied in very short time; also that the medium be capable of inscription at very low (typewriter) speeds; further, the play-back voltage of signal inscribed at either of these two extremes should be essentially the same at high reproduction rates, such that a single reading unit can read (without adjustment or prejudiced reliability) data of either sort. This point requires particular attention, and may in itself (there are other advantages) justify the use of some type of

high speed rotating recording and reading head to be associated with the keyboard transcribing operation (see VII.4 - VII.44).

III.45 Reproduction Speed Range

As in the case of inscription, and for essentially the same reasons, reproduction must be possible at speeds from those corresponding to a keyboard to perhaps 1000 times this rate, and the same techniques should be applicable (see VII.4 - VII.44).

III.46 Durability and Wear

It may be anticipated that in relatively long problems involving many sub-routines reversals, read-backs and substitutions (local erasure and re-recording) may occur hundreds of times; and that furthermore several miles of record may pass over a given recording or reading station. This must clearly be possible without appreciable mechanical wear and danger of mechanical failure, and also without alteration of the magnetic properties of the medium, or serious reduction in signal-to-noise ratio. If, in addition to the hazards of this sort resulting from mechanically moving the medium from one storage spool to another over various pulleys and sliding over the recording head, there is the added factor of a rotating head acting while the wire is stationary, the question of durability and wear will require very careful attention in design.

III.47 Retentivity

This is a specific property of the magnetic medium, indicating the stable level to which the magnetization falls upon removal of the recording excitation. A high value of retentivity is desirable since the reading voltage will thereby be increased and consequently the need for amplification decreased. However, high retentivity is not desirable at the expense of other properties,

for example coercive force, and of S-shaped magnetization curve in the vicinity of the origin.

III.48 Coercive Force

This is the energy (per pulse) necessary to cause erasure (or reversal of the polarity) of a signal; a high value of this parameter is desirable since it implies a very stable recording medium in the sense of III.25. This property is practically the most important in that it tends to suppress background noise, the risk of accidental transfer between turns on a spool (shadow printing) and the accidental loss of signal level. However, the happy circumstance is that many wires combine high coercive force with high retentivity, and furthermore possess the desired S-shaped curve, although their availability in quantity is in some cases not yet assured (see V.1-V.13). Many of the media optimizing these properties do so at the expense of very special alloys, heat-treating and cold-working techniques, the result being frangible and less durable than the more usual alloys.

IV. MAGNETIC RIBBON EXPLORATION: TEST APPARATUS

IV.1 LOW-SPEED LOOP SAMPLE COMPARATOR

Since data relevant to binary storage on magnetic ribbons was found to be not available, and since little or no inference could be derived from claims as to sound and speech recording performance, some apparatus was needed affording a crude survey along those lines. The apparatus pictured in Figure 2 was constructed and found adequate to fill the requirement.

This apparatus consists primarily of a high-quality, two-speed, governor-controlled phonograph motor arranged to drive a sample loop (about three feet in length) past a pair of magnetic reading-recording heads. Refer to Figure 2 it will be seen that attached to the shaft of the motor is a drive pulley of a few inches diameter, which (by selection of pulley size) together with the two speeds of the motor, affords ribbon speeds from 1/2 to several feet per second. The loop of wire passes over a weighted, hinged idler pulley controlling tension, and thereafter over stationary idlers between which are located sample pairs of electromagnetic reading-recording heads. A shielded junction box is associated with these, permitting switching among heads without appreciable noise-coupling disturbance and interaction.

This apparatus was used to compare samples of various wires and tapes as to pulse recording performance, to determine their relative coercive force and retentivity, pulse packing density, signal to noise level, and pulse shape distortion. The procedure of test was to form a loop of suitable length by knotting the ends, in the case of wire, and by overlap and adhesive in the case of tapes. The input signal was derived from various square wave, pulse and pulse word generators (described later) fed directly on the head or through a "D.C. Eliminator" as the case required, in some instances making

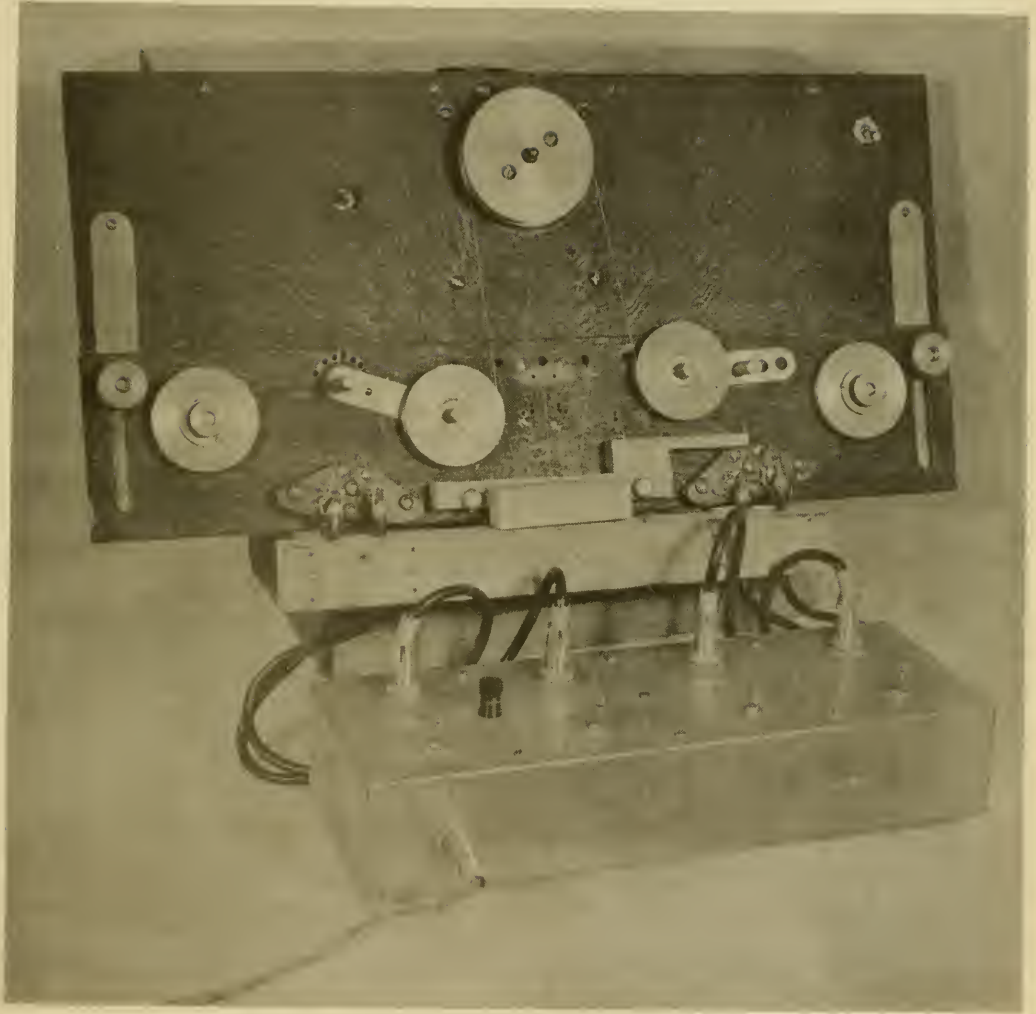

Figure 2
Low Speed Loop Sample Comparator

use of a General Radio 714A amplifier. The output was passed (on occasion) through an R-C integrating circuit, to the GR 714A amplifier and then to a cathode-ray oscilloscope, suitably calibrated (see VIII.4)

This apparatus was also used to compare electromagnetic heads, to test erasing and word pulsing schemes, and as a robot to send pulse-coded sentences from wire samples directly into the Type 19 teletype where they were successfully printed on paper.

IV.2 HIGH SPEED MAGNETIC PERFORMANCE TESTER (PFROTUS)

In addition to apparatus to compare various ribbon samples as to pulse performance, specific magnetic parameters, and geometric packing density at low speeds, there was need for a device for evaluating the high frequency performance of ribbons and heads (avoiding insofar as possible the problems of high-speed mechanical drive) and to determine where the fundamental pulse recording cutoffs lie.

For this purpose it was decided that a precisely machined and balanced rotating wheel of non-magnetic material would permit very high linear speeds, and that if samples of ribbon, wire, etc. were adhered to its periphery, then the relevant high-frequency possibilities of the head and medium could be explored for wide speed ranges without involving serious mechanical problems in the measurement. Accordingly, the apparatus pictured in Figure 3 was devised (and nicknamed "Pfrotus"). - this "plate-model" consists of ten-inch bakelite wheel mounted on ball bearings and machined on these bearings; the whole being supported in a "post and plate" frame. (See Figure 3.) The affair is driven by a 1/20 hp GE commutator motor capable of high speed, having direct elastic coupling to the rotor shaft. A cradle, pivoting and sliding on the frame parts, supports the electromagnetic head, its position relative to the sample being adjusted by crude

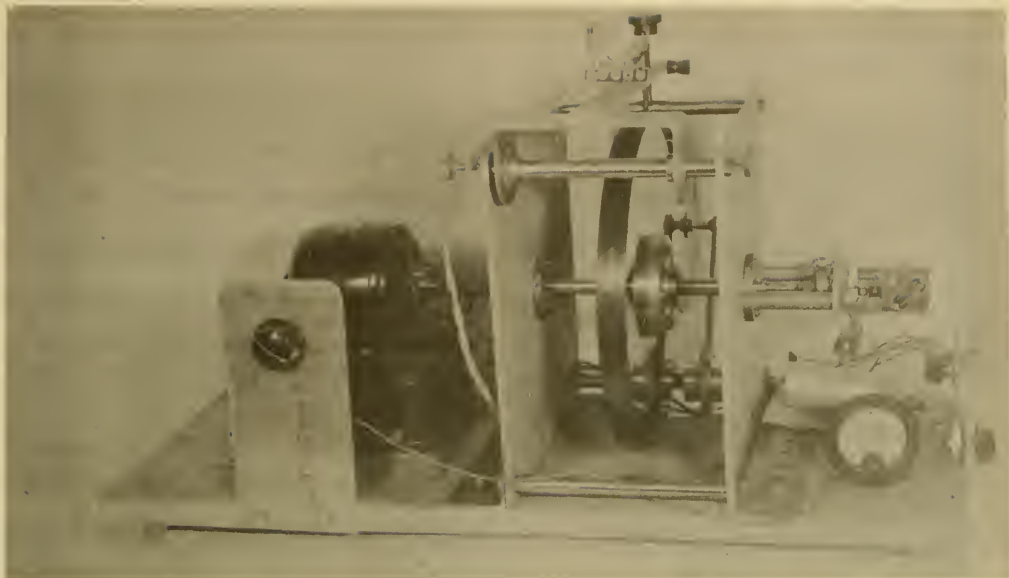

Figure 3
High Speed Magnetic Performance Tester
(Pfrotus)

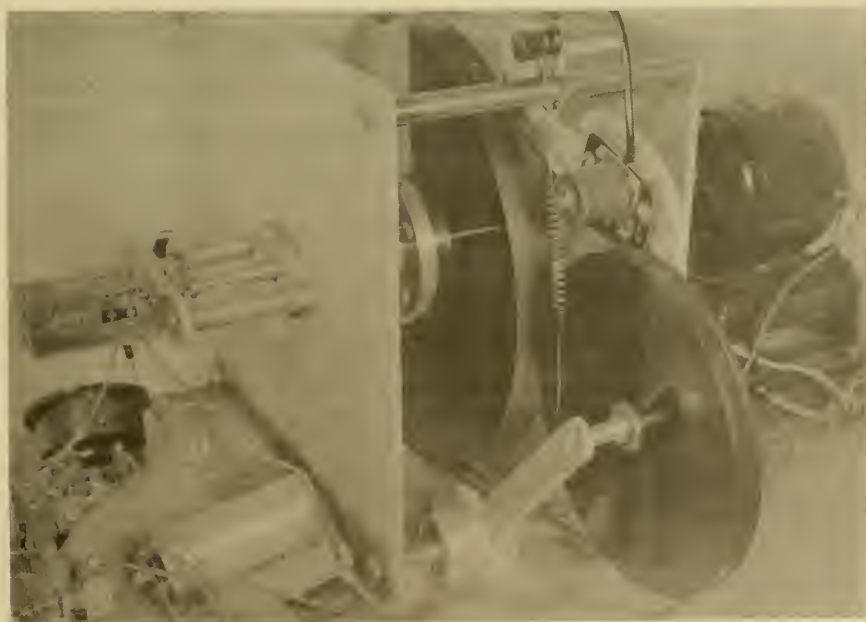

Figure 4
High Speed Magnetic Performance Tester with Outrigger

micrometer thumb-screws, having spring leading to eliminate slack.

Rotor speed was indicated by a miniature (Delco) direct current tachometer connected to the opposite end of the same rotor shaft; this tachometer voltage was read in a small calibrated voltmeter, and a speed stabilizing circuit was provided by "feeding back" the tachometer voltage via a servo amplifier and power supply into the drive motor (See Figure 5). An automobile distributor point cam was also located on the rotor shaft together with automobile breaker points; these may be seen in Figure 5 at the tachometer end. The function of the breaker points was to provide a timing pulse synchronizing the location of the sample on the wheel with the tripping of the oscillograph sweep.

This apparatus performed very well; it had a quite stable speed range from nearly zero to about fifty feet per second. Ribbon and wire samples were glued to the rim of the rotor, the head being adjusted to track closely, and input pulses were applied via a special "Booster Amplifier" described (in IV.4) below. Output voltages were passed through the G. E. 714A Amplifier to a calibrated C.R.O. with and without integrating circuits.

At a later stage in the experimentation with this device it became of interest to rotate short loops of wire and tape, sliding in pressure contact over various heads and at high speed, so that an outrigger pulley was appended, shown in Figure 4 with a loop of Brush Development Company powdered metal paper tape in position.

IV.3 HIGH SPEED MECHANICAL DRIVE TESTER

In addition to magnetic and electrical performance there is the separate problem involved in handling the magnetic medium at high speeds and under high accelerations. It is clear that if digits are to be recorded and

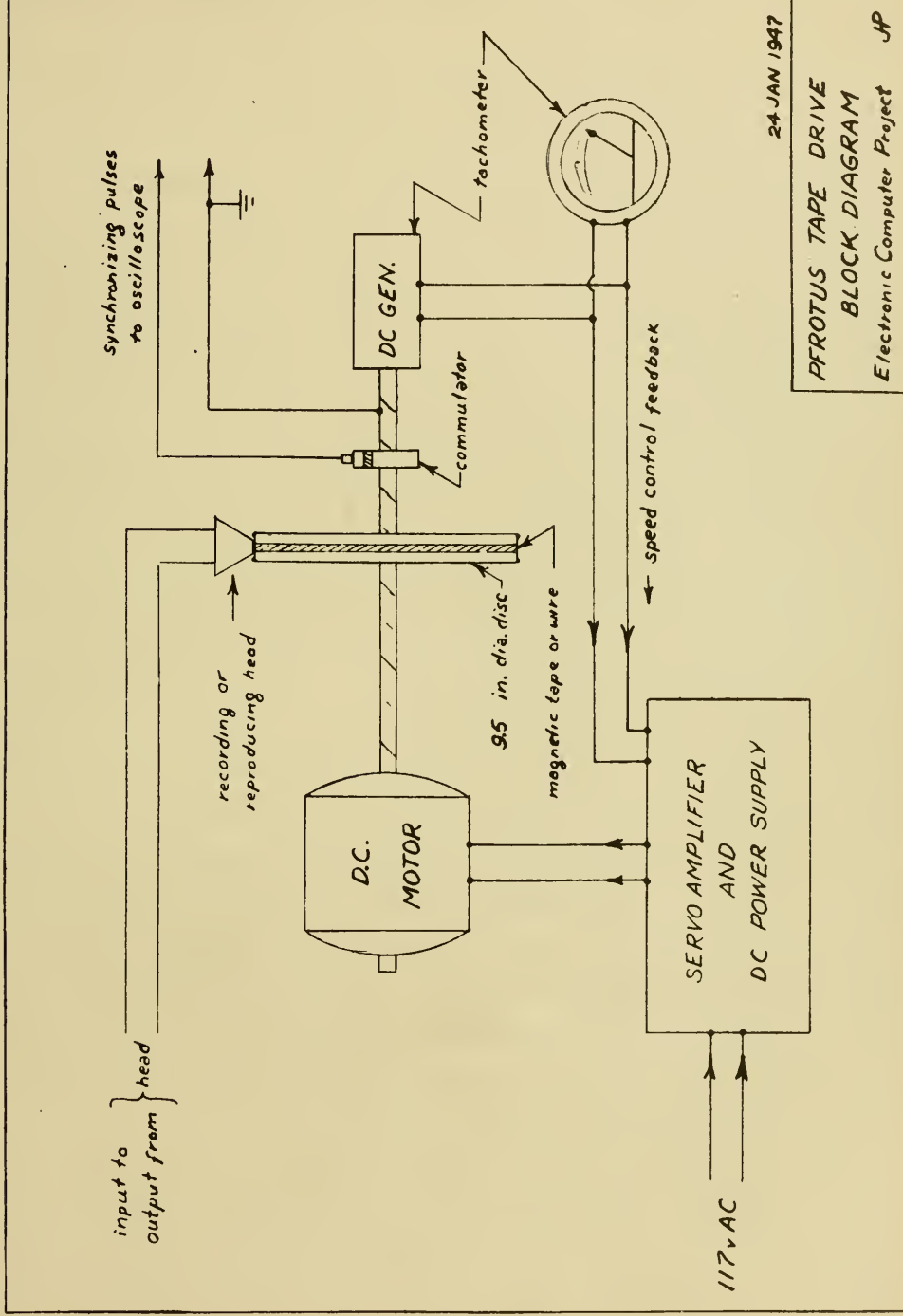

24 JAN 1947

PFROTUS TAPE DRIVE
 BLOCK DIAGRAM
 Electronic Computer Project JP

Figure 5

reproduced at rates ranging from 50,000 to 100,000 per second from media in which the packing density is not microscopic (perhaps 100 to the inch) then linear velocities ranging from 50 to 100 feet per second must be attained, and accelerations on the order of 5 or 10 times gravity are required to minimize time lost during reversals of direction.

This problem may appear technically severe when consideration is given to the physical strength of the ribbon (about one pound, in the case of representative wires) together with the mass of ribbon stored on the spools, which may be something like 10 pounds. However, by abandoning any notion of feeding the wire from one spool to another (independent) spool with shaft servomotors to maintain relative position and tension on the wire, it was possible to devise a relatively simple and satisfactory scheme (see Figure 6).

The experimental high speed wire drive was built as follows: On a single shaft, two reels (spools) are mounted side by side, as close as possible. As may be seen, two ordinary bicycle wheels were used for this purpose (see Figure 6) having grooves about $1/4$ inch deep and $1-1/4$ inch wide turned in their wooden rims. These were chosen because they are rigid, strong and of relatively low moment of inertia. One of these wheels is fixed rigidly to the shaft; the other is mounted on a sleeve so that it can be turned relative to the shaft and first wheel. The means of effecting this relative turning is an enormously reducing worn gear driven by a small electric motor, (see Figure 7), which together constitute a servo-differential, free to rotate as an assembly about the central main-drive-shaft. When the electric motor to this differential system is not excited, the gear train acts like a rigid lock, so that the two bicycle wheels may be driven as a rotationally rigid assembly directly through the central shaft. In test

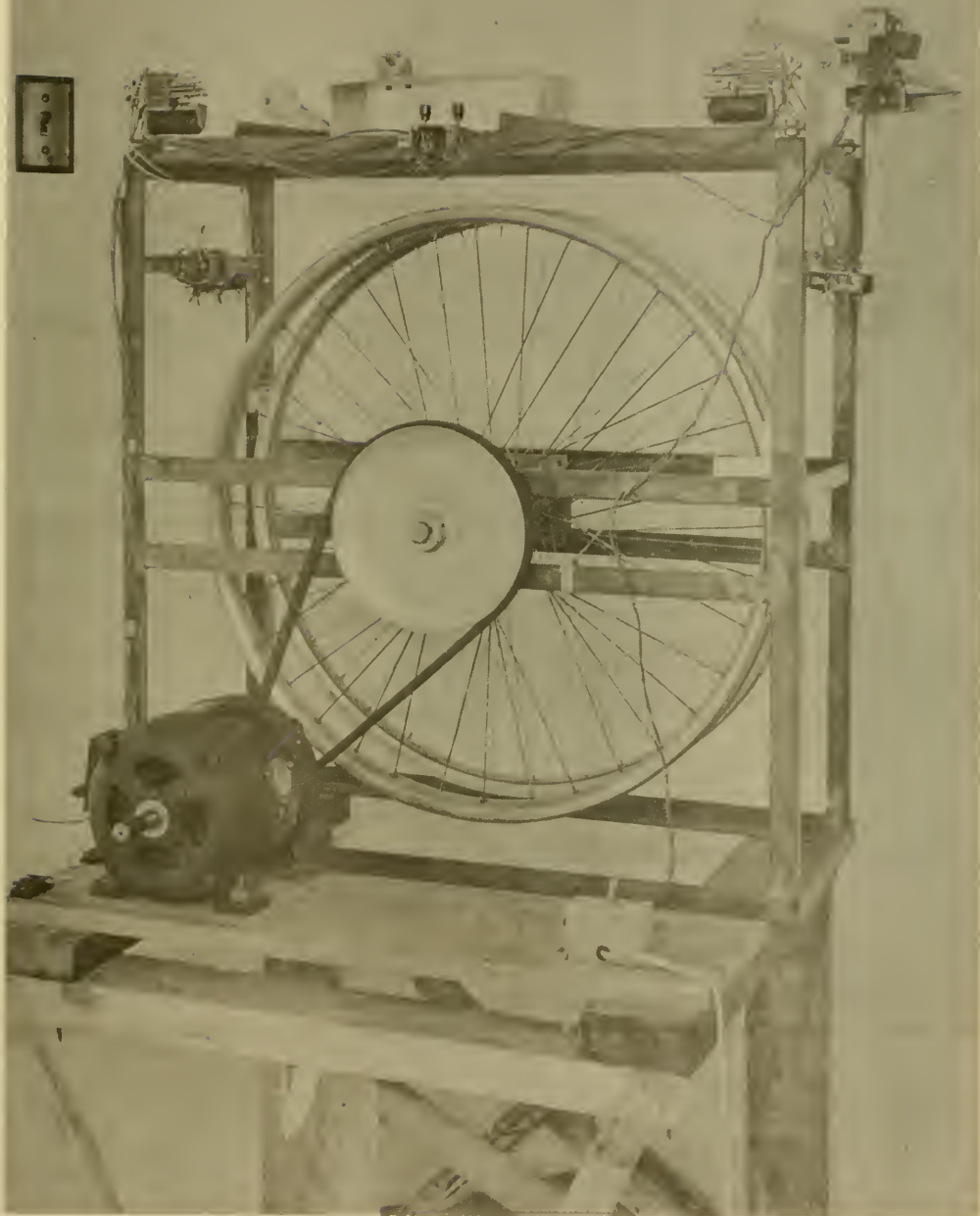

Figure 6
High Speed Mechanical Wire Drive



Figure 7
Close Up View, Differential System

operation this was accomplished by a 1/2 hp 3-phase AC motor, with a suitable V-belt drive (see Figure 6) which was applied at full overload starting torque, allowed to come to full speed and then full reversed by brutally transposing phase scheme.

The handling of the magnetic recording wire is as follows: It is unwound from one wheel via a guide, passes over the two small hinged aluminum pulleys visible on top of the machine frame, and is concurrently wound up on the second bicycle wheel. One of the aluminum idler pulleys is spring-loaded to keep constant tension on the loop; any tendency for the loop size to increase is followed by this idler and after a certain limit is reached a switch is operated by this follower, electrically energizing the differential motor, which moves the wheels relatively so as to draw in the loop; likewise a decreasing size of the loop is oppositely corrected. This servoing operation is of course fully automatic, and occurs with no interference whatever during the rotation and reversal of the main drive as required by recording and reading processes.

For test purposes a station for an electromagnetic head is provided between idler pulleys, and two small level-winding motors with reversing relays are applied near the point of tangency of the wire with each wheel.

The outfit performed very satisfactorily; results are described in V.3-V,39 to follow.

IV.4 RECORDING HEAD BOOSTER AMPLIFIER

In order to record experimentally at the high speeds attainable by the apparatus of IV.2 and IV.3, it was necessary to drive the electromagnetic recording heads with very narrow pulses of high energy content. For this purpose a small "booster amplifier" was devised, consisting of a single stage

having four 6V6 tubes in parallel. (See Figures 8 and 9.) Because of the very high plate current required by this output stage, it was necessary to use an inductance, critically damped, as a plate load. This amplifier was capable of producing pulses of very sharp rise to a value on the order of thirty milliamperes and of about 20 microsecond duration, through the recording head winding.

IV.5 PULSED-WORD GENERATOR

While many tests may be made of pulse-recording on magnetic ribbons, etc., using square-wave generators, intermittent pulse generators singly and in pairs, or threes, and repetitive pulse generators having relatively long intervals (compared to pulse widths) it is still more satisfactory and convincing if truly binary word-entries can be selected at will and recorded and reproduced. For this purpose an artificial pulsed-word generator was devised (see Figures 10, 11, 12), consisting of a ring counter of 20 stages to be driven by a periodic source of suitable frequency, and having "gate tubes" located at each counter stage which may be 'opened' or 'closed' at will, by simply throwing a switch. The result is that one can preset the switches open and closed, in accordance with any 20 binary digit word for which one wishes to produce the binary pulse sequence on the common output amplifier of the gates. Pulsed words produced by this apparatus have the appearance of Figure 21A and can be produced at any digit rate of from nearly zero to 100,000 digits per second, by choice of driving oscillator. The power output of this pulse generator is considerable, producing about 50 volt pulses across a load of 1000 ohms.

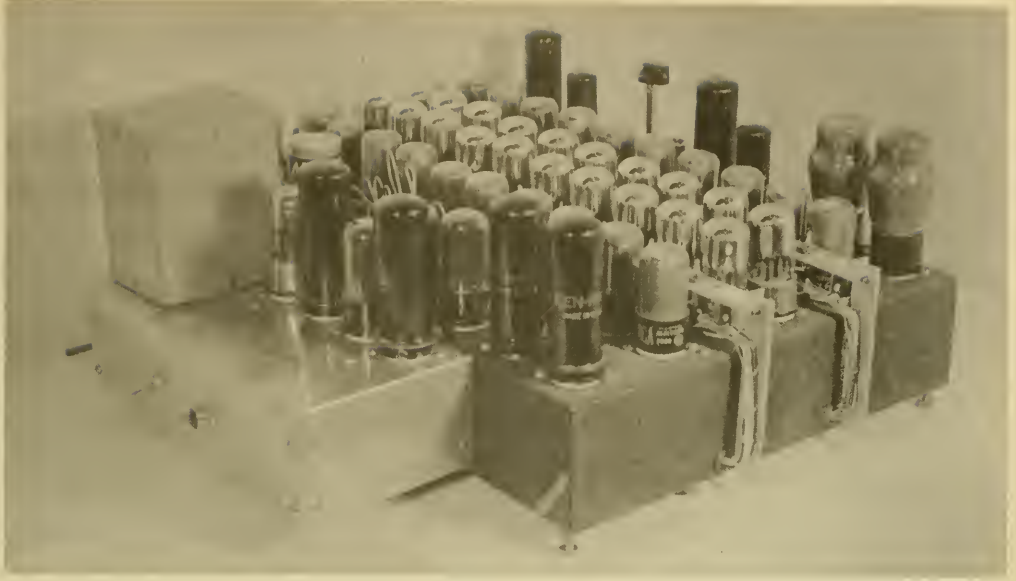

Figure 11
Ring Counter Chassis

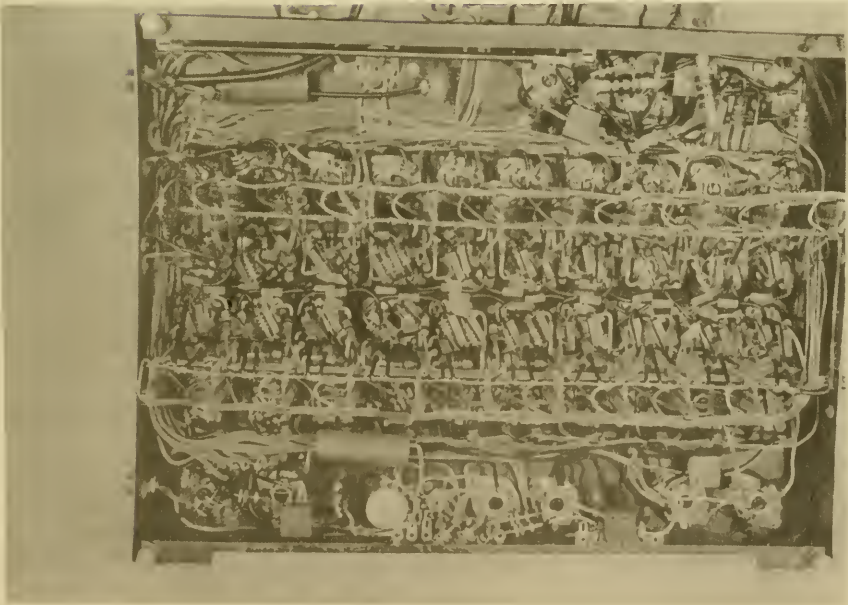

Figure 12
Ring Counter Chassis Wiring

V. MAGNETIC RIBBON EXPLORATION

PERFORMANCE STUDIES

V.1 COMPARISON OF MAGNETIC PROPERTIES AT LOW SPEED

By means of the low speed loop sample comparator (IV.1) various tests and comparisons of the specific magnetic properties of recording ribbons were made; representative of these are the data plotted on Figure 13 (also the dotted curve in Figure 14). These particular data compare eleven samples of .004 diameter magnetic wire operated with standard Brush Development Company recording head traveling at 1 ft./second. The wire was pulsed with square waves at a rate of 100 per second, so that geometric packing was not dense enough to cause any overlap phenomena. The test procedure was to read values of recording current by means of a cathode-ray oscilloscope placed across a resistor in series with the recording head; the arrangement having been previously calibrated. Then the output voltage at the reproducing head was integrated by a suitable R-C circuit, amplified and peak values of the integral read on the oscilloscope.

V.11 Retentivity

This technique, in consequence of the induced-voltage relationship

$$e = -N \frac{d\varphi}{dt}$$

(where e is the voltage, N the number of turns wire linked by the flux φ) gives upon integration

$$\int_{t_0}^{t_1} e dt = -N \int_{\varphi_0}^{\varphi_1} d\varphi = -N[\varphi_1 - \varphi_0]$$

so that the integrated voltage e , occurring at t_1 , corresponds to the maximum value of the flux φ_1 produced in the reproducing head by the magnetic polariza-

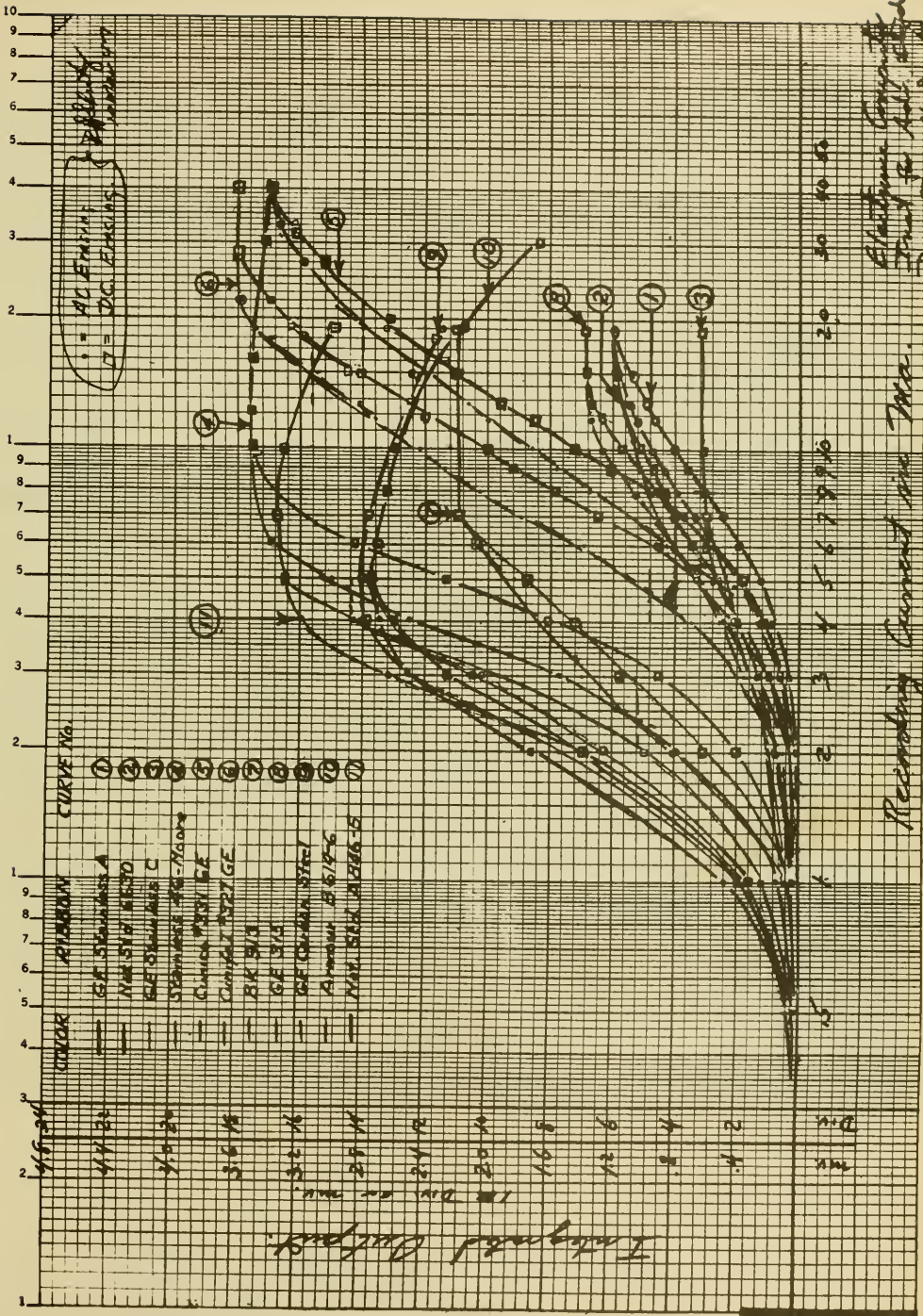

Electrician
 Printed for
 Princeton, N.J.
 Nov. 28, 1978 10/14/46

Receiving Current in Mva.

Figure 13
 Loop sample comparison

16 Oct 1946

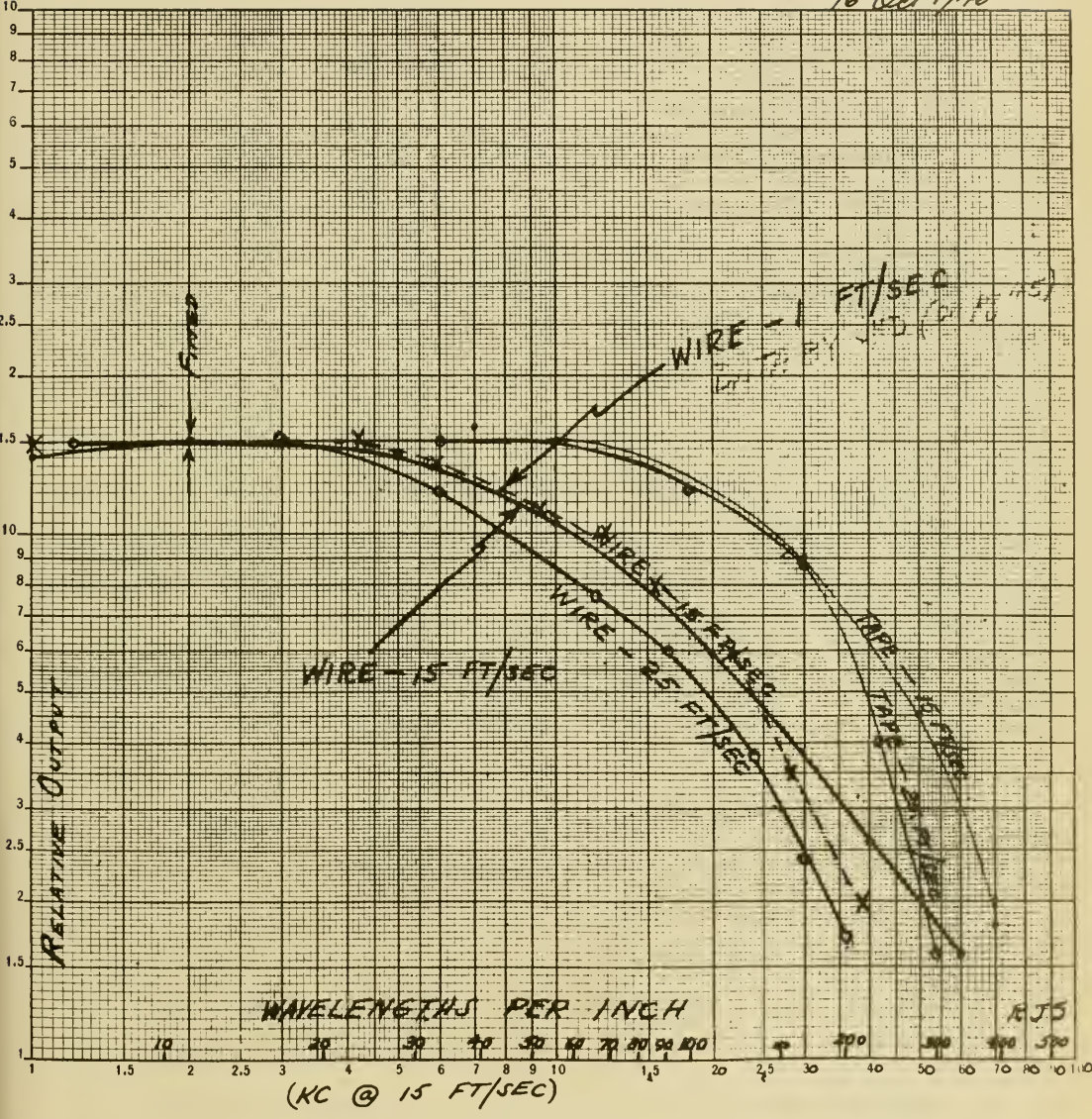

Figure 14
Magnetic recording dependence on density

Reproduction - Geometric Packing Characteristics
Tape - Indiana Steel Company
Wire - General Electric Stainless A
Waveform - Square
Output - Unintegrated
Head - Brush Standard

tion on the wire. If certain reasonable side conditions are allowed to be met, the maximum is proportional to the maximum polarization of the medium, and this so-called "residual" polarization is determined by the (specific property of) retentivity of the material, and by the particular geometry involved (which in this case is held constant among the samples). Hence comparison of the maximum "integrated output" of the samples compares their retentivity. As can be seen in Figure 13 this varies by as much as a factor of 5 among the samples indicated.

V.12 Coercive Force

Another factor of interest is the coercive force; this is not as directly deducible from these particular tests as is retentivity; however, it may roughly be estimated as proportional to the value of recording current which must be applied before the curves start to climb sharply. In fact, the desirable curves are those which do not respond appreciably for a considerable range, and then climb sharply to a high maximum and then level off sharply, as for example do samples 4 and 6.

V.13 Packing Density

A representative sample of the measurements made of this geometric factor at 1 ft./second speed is indicated by the dotted curve of Figure 14. Remark that this phenomena of "overlap" or "interference" begins to appear at about 50 pulses per inch and the effect is becoming quite pronounced at packings closer than 100 per inch, although even beyond this point the output is considerably above the noise level.

This overlap phenomena is clearly geometrical and not a frequency phenomena, as may be seen from the curves which were duplicated at higher

speeds and frequencies. The evidence indicates that the order of magnitude of the effective gap in the recording head is .010 and that the points of maximum flux gradient are separated by this amount, even for an "instantaneous" pulse.

From the representative curves of Figures 13 and 14 it clear that quite practical voltage levels are attained (from .3 to 3.5 millivolts) even with the poorer wires, and in fact any of the samples indicated could probably be used. (Actually, in many of our test hook-ups plain carbon-steel music wire was successfully used.) However, advantage will certainly be taken of the properties of the higher-performance wires in designing the outer memory system M_2 . It further appears that packing densities on the order of 100 per inch are certainly possible using standard Brush speech-recording heads and any of several alloy wires; and that, with suitably refined head design, this figure could be increased at least two or three-fold. The work has not been pressed in this direction, however, since packing geometries closer than .010 were not felt worth striving for at the present stage of the work because (a) their effective use might involve a program of super-minute, "watchmaker's" machine work, for which we are not at present prepared, (b) the closer the packing the more critical of local metallurgical and magnetic properties of the wire is the process of recording and detection, (c) the feasibility of packing 100 to the inch with standard wires and heads was certainly far better than was expected, and consideration may well be given to the question of how best to make use of the capacity and just where it becomes a limitation before making an effort to improve it.

Up to this point no data has been cited on flat tapes of either coated or solid ferromagnetic types. Some data are included in section V.10, to follow, and indicate that appreciably superior linear packing densities may

be achieved with powdered iron coated paper tapes. However, this potentiality has been set aside as of uncertain value toward realization of M_2 at our present phase of development, preference being given to homogeneous wires because they are magnetically quite sufficiently effective, and are considered more likely to be uniform, easy to handle and spool, and mechanically more durable than various composition ribbons and tapes.

V.2 HIGH SPEED MAGNETIC PERFORMANCE

To determine whether the specific magnetic properties of the wire and the geometric packing factor would remain relatively constant if both frequency of pulsing and speed of travel were increased, various tests were made on the high-speed magnetic performance tester, of which Figures 14, 15 and 16 are representative data plots.

V.21 Inscription Speed Range

It can be seen from these plots that "square wave" recording has been carried out at rates up to 90,000 per second and at packing densities up to 400 per inch; and that even at these ranges the signal was still some 18 db. above the apparent noise level. In subsequent work **with the word-group** recording, the packing density has been kept below 50/inch to facilitate study of other variables without interference from resolution difficulties. At high recording rates the principal difficulties seem to be in obtaining sufficiently violent pulses to drive the heads at these **repetition** rates, and there is some evidence that as speed and repetition rates are yet further increased, the limitation will be in the head performance. There is no clear evidence of appreciable limitation in inscription rate due to the properties of the wire or tape at speeds in the neighborhood of 100 feet/second and pulse repetition rates near 100,000 per second.

Figure 15
Magnetic recording response

Reproduction - Frequency Characteristics
 Tape - Indiana Steel Company
 Wire - General Electric Stainless A
 Waveform - Square
 Output - Unintegrated
 Head - Brush Standard

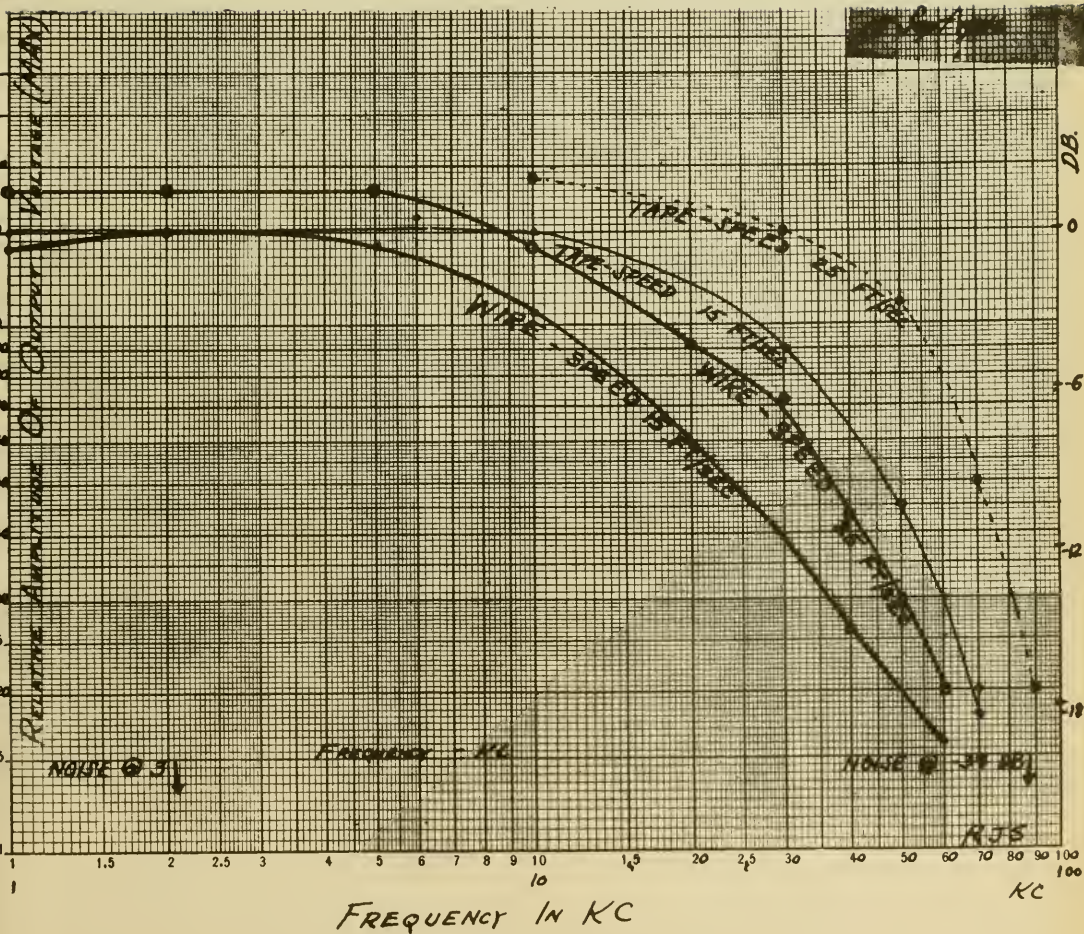

Saturation Characteristics
 Tape - Indiana Steel Company
 Wire - General Electric Stainless A
 Waveform - Square
 Output - Unintegrated
 Head - Brush Standard

18 Sept 1946

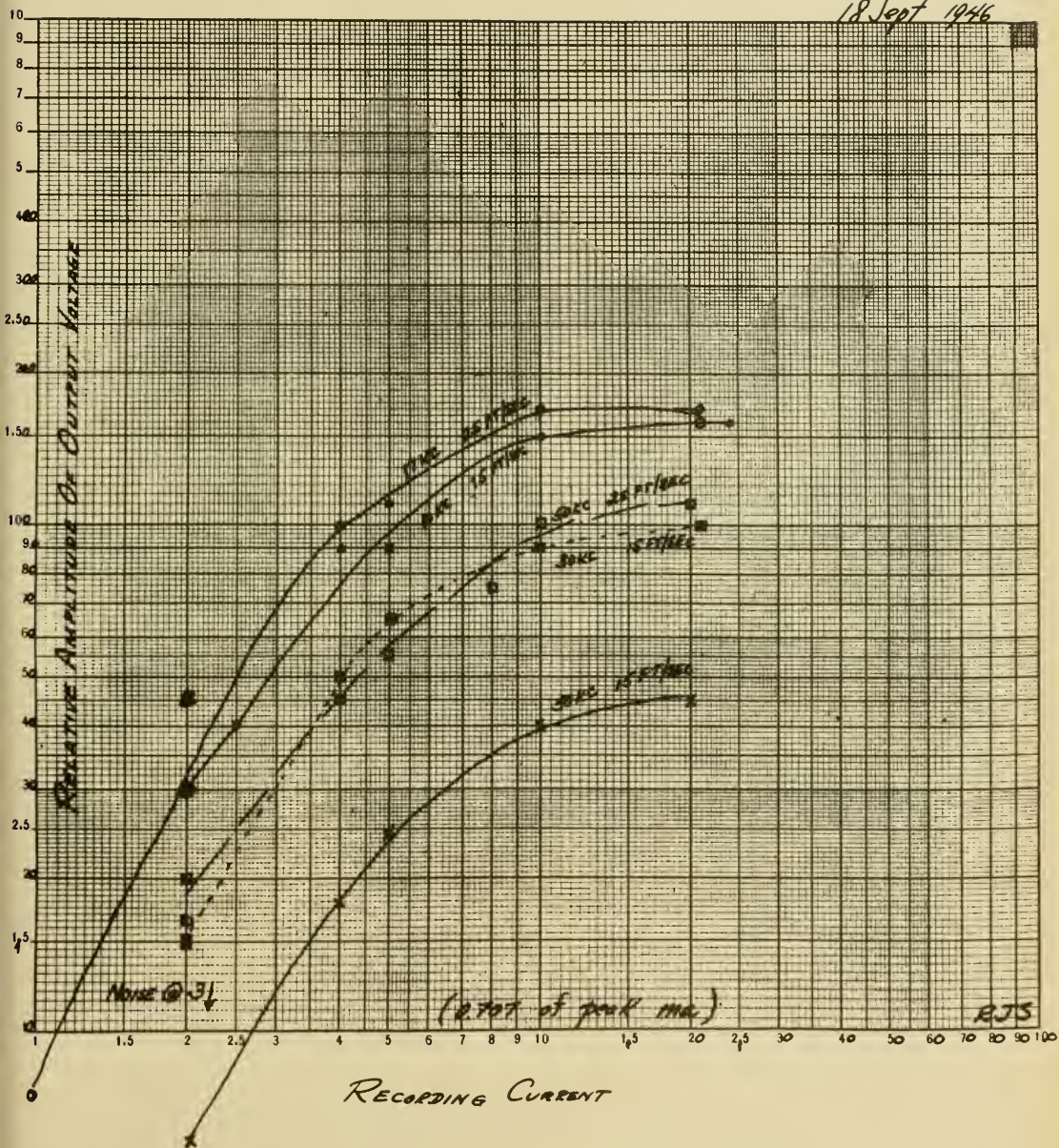

Figure 16
 Magnetic Recording Response

V.22 Reproduction Speed Range

Pulses and pulse-groups were recorded under standard conditions and then reproduced at various speeds up to those producing nearly 50,000 pulses per second; the decline in performance was slight and there was no evidence of any fundamental limitations to play-back near these figures.

Representative data of this type for square waves are Figures 14, 15 and 16 which extend up to 80 or 90 kc but show speeds only up to 25 feet per second, hence the indicated decline in response is largely due to geometric overlap resulting from packing more than 100 pulses to the inch. Here too there is evidence that the powder-coated tapes are somewhat superior to solid metal wires.

V.23 Packing Density

The effect of overlapping pulses is relatively independent of speed as may be seen from Figure 14, there being little difference in rate of decline with increasing density, whether for 1, 15 or 25 feet/second velocity. This factor is indeed essentially geometrical throughout the range of conditions tested.

V.24 Output Level and Amplification Required

The voltage outputs produced by standard Brush heads ranged from about a millivolt at 1 foot/second to proportionately greater values at higher speeds. Values in this range are quite easy to amplify; however, if low operating speeds are of interest, serious consideration should be given to changes in head design, and in particular it is considered that by merely re-winding the coils gains on the order of 10 could be made.

V.25 Effects of Head Design; Saturation Phenomena.

It is believed that the design of the standard heads could be considerably improved for pulse recording work. Among other features, the pole tip design is such as to produce a relatively large self-inductive flux compared to that reaching the wire with the result that local saturation of the tip may occur, and the effective gap relatively wide. Other details such as the design of the winding and core material deserve particular attention if operating on pulse rates in the range between 50 and 100 kc. Some thought and attention has been given this question, but it is considered that any such refinements would at this stage of the work be premature.

V.26 Signal to Noise Level.

It is of interest to remark that the signal-to-noise ratio throughout the range of speeds and rates discussed never was found to be near a bothersome level, and in fact was always above ten-to-one. This does not imply that higher noise levels present in the operation will not whittle down this advantage, and in fact the ratio should by all means be kept as high as possible.

V.27 Fatigue and Durability.

When the high-speed magnetic drive was operated with the outrigger pulley (see IV.2) a loop of wire or tape was used, in rubbing contact with the recording head. It was observed with some interest that operation at quite high speeds (circa 1500 RRM) for periods of several hours did not rupture either coated paper tapes or wire loops, nor did failures occur in the knots in the wire or glued lap-joints in the tape. The powdered coating on the paper tape did tend to glaze after a while but this had no observable effect on the magnetic performance. (These results were achieved using a specially polished magnetic head. As received from the manufacturer the heads were rough enough to wear

this powdered coating severely after about 10,000 passages.)

V.3 HIGH SPEED MECHANICAL PERFORMANCE.

Experiments conducted with the high speed mechanical drive tester (IV.3) were carried out with plain carbon steel wire, and brush plated wire BK913, both .004" diameter. Observations were essentially as follows.

V.31 Packing on Reel.

No trouble was experienced. It has been originally thought that level-layer winding might be necessary due to the risk of one turn becoming caught below others; this was not experienced, however. From all appearances the theoretical "winding table" density of 80,000 turns to the square inch of spool could actually be realized, and that there is no real risk from centrifugal phenomena or other causes, for speeds in the neighborhood of 50 ft/second.

V.32 Tension on Recording Head

The loop tension was set by spring adjustment at about half a pound; this was found very satisfactory in that it held the wire securely against the recording head, and operated the differential follow up switch on the idler pulley with no particular trouble.

V.33 Travel Speed

The motor and pulley drive arrangement used resulted in wire speeds of about 50 ft/second, which is high enough for any presently contemplated purpose. However, at some future time it is intended to increase this speed to the point where trouble begins, of only to determine the nature of such difficulties at what point they will first appear.

V.34 Acceleration and Reversal

The acceleration was accomplished by means of a $\frac{1}{2}$ hp-three phase induction motor, which appeared to reach full speed in less than a second, and to

reverse in something less than $1\frac{1}{2}$ seconds from full speed in one direction to full speed in the other direction when the phase sequence is reversed. The accelerations implied by these figures are roughly two or three times gravity; by braking, higher accelerations were applied. On no occasion did the wire fail due to acceleration or to high speed, and in fact there was no evidence of appreciable extra loading on the wire loop during such trials.

V.35 Vibration.

While no difficulty of operation either mechanically or in the voltage pickup during reading was detected which was attributal to vibration, it was observed that if the adjustment of the idler pulleys or head was not quite carefully made, flutter and vibration could be produced in the longer unsupported spans of the loop. The cure was simple; adjust the pulley or head into alignment. However, in a more refined design of outer memory storage, long unsupported spans of wire may well be avoided.

V.36 Wear and Fatigue.

No signs of wear or wire fatigue were detected after some twenty or thirty runs. The only wire breakage which occurred resulted simply from allowing the wire to get off the head or out of the reel and tangled with the drive. In such cases snarling was severe. Knots in the wire gave no trouble in any part of the mechanical feed.

V.37 Knotted Splices.

Some half dozen knotted splices were placed in the wire and observed; none failed or gave evidence of appreciable wear.

V.38 Electrical Output Performance.

Electrical recordings and readings taken from the standard Brush head indicated no new difficulties, and were in fact exactly as indicated by

the tests on the high speed magnetic tester (IV.2). Some quarter million pulses were recorded on carbon steel wire and read many times without difficulty. These were allowed to remain on the wire for several weeks and then read; a very slight but noticeable "transfer printing" between turns on the reel were noticeable. However, this was well below the signal level and could easily be excluded by discriminating circuits; moreover carbon steel wire is certainly low in magnetic performances and it seems certain that with any of the alloy wires this would not occur. This point will be verified by later tests.

V.39 Effect of Dirt and Cleanliness.

Some of the wires tested in the high speed mechanical drive had a barely discernable film of oil protecting their surface; however when several miles of such wire were run through the reading head and this lubricant accumulated persistently in surprisingly large clots of grease which were very difficult to clean from the head. Care should be taken to see to it that any wires used are absolutely clean, and that they are strictly grease-free! Further, consideration will be given to the inclusion of wiping pads of felt or other material in a more refined design of M_2 .

VI. OUTER MEMORY COMPONENT DESIGN STUDIES

VI.1 COMPONENT OVERALL SIZE, CAPACITY, PROPORTIONS.

Based on the data and tests outlined above, it is possible to specify the range of capabilities and essential design constants desirable in M_2 using currently available heads and wires.

First, for a machine operating at the contemplated rates fifteen minutes is an enormously long waiting time, so that perhaps 1000 seconds running time for each ribbon unit in M_2 would represent an upper bound. If the inscription and reading rates which are conceivable at this time be set at 10^5 characters per second, this will imply a total capacity for each spool storage of 10^8 binary characters. The packing of .004 wire on spools is near 10^5 per square inch and if the linear digit density be taken as 100 to the inch, this would call for reels of about 10 cubic inch capacity. This quantity of wire would weigh about three pounds, and so would be quite manageable by relatively small motors (perhaps 1/10 hp.). A suitable diameter for the reel would be about 6 inches giving a circumference of about 20 inches, and if the channel were 1/2 inch deep and 1 inch wide, the requisite capacity of 10 cubic inches would result.

To operate at 10^5 pulses per second the linear speed would have to be about 100 feet per second which would be about 60 turns per second or 3600 RPM for the reel drive shaft - which seems a very reasonable speed. At the beginning and end of a run, when one reel is loaded and other nearly empty, the differential rate would be about 600 RPM or 10 RPS, which appears feasible.

VI.11 Drive Scheme.

If M_2 be built around such units, in banks of perhaps ten, the drive could be either by electric clutches or other controllable take-offs

from a single drive shaft; or by means of individually controlled motors for each unit. Likewise the differential could also be of controllable clutch or motor type. Essentially the same loop arrangement and follow-up system as used in the test outfit (IV,3) could be adopted with high expectancy of success.

VI.12 Real Design.

It would be desirable to design the loading-and-unloading reels as a unit, one being free to turn relative to the other, but the pair being always handled together. These should be arranged to slip over the end of a stub driveshaft, so that at any intermediate point in the process the two reels could be slipped off the head and pulleys, twisted relatively to draw up the loop, and filed in the library. The reels could be made of aluminum to reduce weight.

VI.13 Loop Tension.

This could be made adjustable, the minimum safe operating value being used to reduce head wear. Sufficient tension should also be maintained to produce tight packing on the reels.

VI.14 Run and Reversal Speeds.

As indicated, running speeds of 100 ft./sec. would be desirable, and the possibility of using higher speeds to reach a remote part of the record should be considered. Rotational speeds corresponding to 300 or 400 feet per second may be perfectly feasible, particularly if the wire is lifted out of the head track and run on pulleys during such "non-reading" runs. Reversals at acceleration of at least 10 g. seem quite practical, and it would be desirable to include a friction brake operating automatically as zero velocity is approached.

The only need for operating speeds higher than about 50 feet per second results from the need for access to remote parts of the ribbon record, since at 50 feet per second the Selectron Memory, M_1 , could be loaded or unloaded in 5 seconds or less. However, as indicated in section VII.1 (to follow) reliance is placed upon the operation of reading to keep track of position on the tape record. Hence for high speed remote-hunting runs reading of word groups will still be necessary at whatever speed is used.

VI.15 Head Design.

In view of the above remarks, it may be worthwhile to consider the design of special high-speed reading heads, capable of reading word-groups at high speeds without friction contact with the wire. Various ways of accomplishing this have been studied, but no experimental work carried out since the need is not urgent at the present stage of the development program.

VI.16 Breakage Repair.

Attention has also been given the problem of breakage, both in connection with the avoidance of snarls when this happens in normal operation, and in welding or otherwise making satisfactory joints. However, evidence to date indicates that breakage in operation will be of rare occurrence, most breaks being the result of manual mistreatment.

VI.17 Automatic Control.

This does not appear to be as difficult a problem as originally thought. The servomotors seem to operate perfectly satisfactorily from on-off switches, together with an on-off brake. Position will be retained by word counting, and although many reel-units will constitute the final battery of M_2 , only one of these need operate at a time, the others being held stationary by mechanical brake. Consequently only one interpreter-

indexer and position counter is required, the position of the standby units being temporarily stored in the Selectron memory M_1 . No elaborate mechanical servo-control need be used to avoid overshoot during hunting operations, since this can be avoided by using electronic switching to "out in" and "out out" as the range of interest is passed.

VII. INPUT-OUTPUT TRANSCRIBER COMPONENT STUDIES

VII.1 REGISTRATION OF RIBBON MEDIA

The problem of registration on continuous ribbon media could conceivably be solved in several ways: 1) By providing an auxiliary channel for index numbers or marks, possibly recorded and detected by different means than that used for information; 2) By some scheme of geometric indexing or measurement; 3) By index numbers recorded and read by the same means as the data proper, but interposed throughout the data; 4) By marker groups (pulses or blanks) interposed throughout the data, and counted (rather than read) by the interpreting system.

VII.1.1 Requirement of Asynchronous Operation.

Of the above methods, 1) is ruled out by several arguments, essentially along these lines: There is only one optimum method of recording and reading from a ribbon or other medium, and that logically this should be used for the entire memory function, both data, orders and identification. If, for example, optical "spotting" on the surface of a wire or tape is more satisfactory than magnetic "spotting" (which is most unlikely) than this should be used for the entire memory function. The fact is that the magnetic properties of metallic wire are chosen for the purpose because they seem reliable (and are volumetric) and unaffected by wear, surface variations, etc. and that the ferro-magnetic properties of drawn wire are by nature of the manufacturing process more likely to be homogeneous and statistically reliable over lengths of a few thousandths of an inch, to an extent not rivalled by other recording means. A further argument against method 1) deals with the practical aspects of having two independent types of recording on a single wire. Clearly if one of these is used to record index numbers, and the other to

record corresponding data entries, an error in either will disrupt the operation of the system. Hence the importance of reliability in the two records is equal, and the probability of system error is proportional to the product of the reliabilities of the two. If the reliability of the index record is just equal to that of the data record, and if (a) the incidence of failure is independent of the number of reading systems used; and also if (b) the probability failure of each individual character is entirely independent of everything else, then the two separate records will just equal the reliability of the combined record, for any given system of notation. If either method is more reliable, then their joint performance may be somewhat better, and an optimum system could be worked out; however, this seems unlikely. In fact what seems likely is that the dual system, which requires a complete duplication in each channel of detecting and checking circuits, plus in addition a synchronizing (inter-leaving of index and data during inscription) system which must itself be checked, will simply lead to a compilation of the shortcomings of both systems. Finally, even though the index system may be pre-inscribed, certain technological difficulties persist; for example, if surface markings with optical sensing be used, it is unthinkable to be able to produce a mark for each character, and even one mark per word will constitute a serious problem. If the auxiliary index is to produce not location numbers but merely a marker per word, one may well ask what this accomplishes that is not automatically accomplished in the act of reading the word. Method 2) is quite feasible if (relatively) short lengths of wire can be rigidly retained in some geometric framework, as in the spiral-cylinder scheme (III.14). Geometric indexing by placing two channels in parallel, as on flat tape, and

THE UNIVERSITY OF CHICAGO

PHILOSOPHY DEPARTMENT

PHILOSOPHY 101

LECTURE NOTES

PLATO

THE REPUBLIC

THE ALLEGORY OF THE CAVE

THE PHILOSOPHER KING

using one for location and the other for data are simply less sophisticated means of accomplishing 3) and 4), probably being more wasteful of capacity. Since the use of flat tape is not contemplated at present these methods will be set aside in further discussion.

It is important to note that since the input and output to the machine are essentially serial processes, and since the wire reels are mechanical devices having appreciable inertia, imprecise geometry (compared to pulse packing dimensions) and imperfect speed and position control, the design of M_2 can be greatly facilitated by relaxing the timing tolerances of M_2 completely; that is, by using asynchronous operation of M_2 which is made possible by the happy choice of an electronic inner memory M_1 . The properties of M_1 are that it can receive and store information about 100 times faster than M_2 ; it can receive purely serially, and can be made to operate as a slave to M_2 ; oblivious to time, and recognizing only the completion of certain transfer operations from M_2 .

VII.12 Sequential Coding; Markers vs. Blanks.

Presumably, blank (unmagnetized) spaces between word-entries and binary characters could be used as markers, and by counting such "blanks" with electronic counters, word index numbers could be preserved. Two objections to this are 1) the doctrine that "absence of a signal should never be used as a signal" which in practice amounts in this case to the belief that the zero-magnetic-energy-state is apt to have a high noise level after a wire has been used often, and is less stable than either directions of pulse saturation; 2) the speed variation over which reading is desired is so great that the intervals between pulses at low speeds compare to allowable intervals

between words at high speeds, so that the counting-discriminating circuit would require some correcting term for speed, as by a voltage feedback from a tachometer on the reel-shaft, all of which is complicated and poor practice.

Hence the asynchronous indexing should be deliberately generated marking pulses occupying gaps between word groups and characters.

VII.13 Coding by Index Numbers vs. Counting Markers.

There remains the point of whether the sequential coding should be by index numbers between words (or groups) or merely be accomplished by recognisable marker pulses. This question is less easily settled than some of the others. Clearly the advantage of the index-number method is that location can always be "found" at the next index number if it becomes less; also no external counter but merely a register is required.

However, these advantages of the index number system evaporate rapidly when the detailed implications are considered. These are 1) for M_2 units holding 10^8 digits each, the index numbers will be of length comparable to a word; so about half the record will be lost, unless they are placed every N words, in which case an N stage counter and markers must be used and the system becomes hybrid; 2) if words and index numbers are of about equal length, some means must distinguish them, which re-introduce a counter; 3) if location is lost, the "damage is done" and the routine interrupted, in which case it is a doubtful advantage to know where things are very quickly; 4) a marker system of a particular variety (Later to be described) ties in very well with the standard type 19 teletype to be used, and affords many checking features capable of disclosing errors.

It appears quite clear that for the rudimentary computing instrument

which is our first goal, having non-automatic unidirectional wire drives capable of merely "loading" and "unloading" the selectron memory M_1 upon command, the particular marker system described in section VII.52 is among the best of the contenders. At a later stage in the development, when automatic controls and further refinements are under examination, further attention will be given to the possibilities of sequential index numbers associated with checking circuits and features.

VII.2 TYPES OF FAULT: RISK

All elementary operations carried out in the computing instrument involve memory-retention of information, or transfer of information, or both. Such operations may, in general, be checked by the inclusion in the machine design of checking features of one sort or another, requiring various amounts of additional apparatus. Clearly checking can be accomplished at the elementary cell level, at the component level, or at the organ level; in each case including all the encompassed memory and transfer operations. The choice of level and specific methods of carrying out such checking is dependent upon many hypotheses as to various fault-risks and complications involved, having both schematic and structural implications. Most of these questions are unsettled at present.

VII.21 Disclosed Faults.

If a particular component has in its design certain checking features, these will disclose the corresponding faults and signal their presence, either by stopping the normal process and actuating a "fault signal" or by re-routing the process to effect repeated attempts at correct operation, or perhaps to isolate and identify the faulty data. In any event, correct operation of

the checking circuit will disclose their presence by special signals.

VII.22 Undisclosed Faults.

It is a priori clear that no checking system can be both complete and infallible, and that in general such systems merely reduce the probability of undisclosed error; at the same time introducing complications in the form of extra apparatus, extra operations and extra operating time. In short, checking increases the reliability of the instrument but tends to reduce serviceability. Any practical checking circuit leaves some possibilities of undisclosed faults, and most practical checking circuits deliberately neglect certain fault possibilities; it is accordingly convenient to define the "correct operation" of such a circuit as operation whereby all intended checks are performed correctly and the verified operations signalled as proper or faulty; "incorrect operation" being an unsignalled fault of the circuit itself.

VII.23 Systematic Faults and Random Errors.

It is convenient, and quite illuminating, to classify all failures into two groups:

A. Transfer Failures

B. Memory Lapse Failures.

Type A faults will certainly tend to be systematic; that is, to occur in a certain stage in the process when two elements are ordered to interchange information. Unless perturbation is introduced somehow in the order itself, or in the sensitivity of the elements involved, "A" faults will occur each and every time a certain order is given to transfer in a particular manner.

Type B faults may result from any of several causes: elapsed time,

attempts to transfer between memory elements involved; influence of concurrent operations elsewhere in the machine or even outside the machine. Nearly all such memory lapses will likely be due to causes fundamentally systematic, but the combination of such causes may be so involved as to be virtually untraceable, and therefore apparently random. Memory lapse failures associated with time may, of course, be due to the use of memory elements having a "normal" (minimum energy) and an "excited" state as binary conditions so that the tendency is to drift toward the unexcited state as time elapses; or such lapses may occur in elements having completely symmetrical binary states as a result of receiving accidental or random pulses of equal probability throughout time.

VII.24 Element Failures.

Certain failures may be so systematic as to disclose themselves soon after occurrence by evidencing manifestly absurd results. In high speed electronic circuits it is likely that tube heater failures, wiring transposition, opens and shorts will be of this type.

VII.25 Noise level; pickup; stray coupling.

Noise of essentially random type will very likely exist in the input data read from the magnetic wire memory M_2 . However, this noise will likely appear as voltages which are of bounded rather than of random distribution; and will (by all indications to date) lie well below the signal level. The question of under what circumstance and with what frequency such noise will simulate data pulses can only be settled by statistical tests; but if these disturbances do not operate the first binary element into which the message feeds, they will thereafter be filtered (by non-linearity) and completely removed at this stage and will not thereafter appear in the machine. Elsewhere, tube noises will introduce significant random variation only where the voltage

sensitivity level falls well under a volt, which will be avoided by design, microphonic and leakage pick-up, as well as stray coupling due to inductive and capacitative effects must be particularly insulated and shielded against, since these may lead to the most difficult types of combinatorially systematic errors.

VII.26 Positive Action Checking.

As stated elsewhere, the general scheme of checking is by no means obvious at this time; however, certain implications of checking by duplication, closed cycling, etc. may deserve a little attention at this point.

Consider first the problem of checking a memory element, component or organ. If appreciable risk of type B failure exists, memory can be checked only by duplication. In the case of either memory component M_1 or M_2 this duplication appears to be highly undesirable on the basis of excessively increased bulk. Further, it is important whether the memory organ is essentially symmetrical with respect to its two binary states (VII.23) or whether it tends toward some "minimum" state corresponding to either "0" or "1". If the cells of the organ are symmetrical, their probability of accidental lapse to either state is the same, and a comparison check is always meaningful. If the cells are not symmetrical but systematically tend to lapse toward 0 or 1, then when duplicating this asymmetry can be corrected; that is, by always storing a 1 in one of the memories and 0 in the other, verification occurring upon sensing a difference between the two memories.

The notion of positive-action checking, - that is, that the absence of a signal should never be used as a signal, is based upon the idea that many circuit elements are fundamentally asymmetrical if operated at two

binary points 0 and 1; where 0 corresponds to the absence of energy and 1 to the presence of energy. Feed-back checking circuits may consist of cascades of "OK" gates having two states but no memory, and of various binary elements having two symmetrical positions with memory. Open circuits in gates generally fail to transmit, indicating null; this occurs when a tube heater breaks or when a power supply fails. Short circuits may or may not cause transmission. Insistence upon transmission of information by signals of finite energy implies the belief that the class of faults represented by tube and power supply "opens" are more common than signal-simulating "shorts", and also the belief that certain binary elements "stand by" at zero energy level rather than at finite energy levels of opposite sign. In fact, if both 0 and 1 are represented in all elements by finite, different, symmetrical energy levels (any +E and -E) positive action checking or null action checking between elements moving these states are no longer significantly different, and advantage is being taken of the existence of three stable states in the element - two symmetrical, representing proper operation, and one abnormal, or "open fault" state. Note also that a coincidental "null" check between pairs of such elements due to both having open circuit is of no significance since the dead element does not relay any signal.

Consider next the question of transfer and its relation to memory. The reliability of transfer between memory elements may be affected by the state of the elements; and again the memory state of the transmitting elements may be affected by the act of transferring or reading memory state. The first possibility implies asymmetry of susceptibility to transfer, and may, with sufficient diligence, be minimized by the artifice of "push-pull" duplication

along the lines indicated above. The second possibility is more serious, for if it exists successive observations before, during, and after a transfer operation either into or out from such memory elements cannot be made, and the transfer to or from, hence the state of element cannot be checked except by complete duplication including terminal transfers. Further, such an element even though checked by push-pull duplication with another similar element, is very unsatisfactorily checked, because (for example) in attempting to effect the read-out transfer such an element may come into agreement with the receiver element by premature clearing of the transferring element so that the transfer is improper or reversed, and this may not be disclosed by simple assymetry. In this case no distinction can be made between "failures to transfer" and "memory lapse"; and the situation may become almost hopeless if the two binary states are furthermore not symmetrical.

VII.27 Coincident Faults.

Checking by parallel duplication, or by feedback, or by any method of repeated independent observations essentially utilizes the low "product" probabilities of coincidence. In general, other coincidence checks are often possible and desirable in addition to these checking digit-wise all the characters in an entry. For example, an entry may be standardised or "coded" as to length, may contain certain interspersed coding pulses, or may be verifiable by (say linear interpolation) relationship to prior or succeeding data. Some of these points are exploited in schemes here contemplated for recording on and reading off the serially coded magnetic wire. All parts of the wire will be occupied by either indexing marker pulses or by message, and these will always be in symmetrical binary states, zero energy never being used.

VII.28 Minimization of Overall Risk.

It is seldom if ever possible, at a state of development corresponding to that of the electronic computer field, to minimize the overall risk due to the many failure hazards involved. However it is thought that the question of risk and checking is very basic and that an attempt to explore and analyze it concurrently with the development of the apparatus will certainly point the way toward that minimum.

VII.3 A WORKABLE RUDIMENTARY KEYBOARD TO RIBBON TRANSCRIBER (T_1 , T_2).

In order to make available a unit able to act as T_1 and T_2 at as early a date as possible, consideration has been given to the possibility of making minimum essential changes to the type 19 teletype set. These changes will entirely aim to make operation possible and only incidentally will checking and verifying processes be facilitated.

VII.31 Capabilities of the Type 19 set.

The type 19 Teletype has a keyboard suitable for our purposes without modification ^{ex}cept for changing the buttons on the keys. This keyboard is capable of operating at a rate of from five to ten characters per second, and actuates a mechanical interposer system which simultaneously codes a group of five perforating punches, a five-contact sequential electric switch, and a type bar selector. The operation of a character-key on the keyboard therefore simultaneously prints on a page of paper, perforates a tape with 5-code, and emits a sequence of five electrical pulses. Likewise the unit can type and perforate tape from 5-code electrical pulses received from sources outside the machine.

VII.32 Simple Modification to Type 19 Teletype Set.

Clearly this outfit requires little modification to render it operable as a terminal unit (T_1 or T_2) in the computer system. The electrical code used is entirely suitable for binary coding of decimal digits, except that in the normal operation of the set each group of 5 pulses is preceded and followed by a "warning" and "conclusion" pulse; these can be eliminated by replacing a simple commutator with another of different segment arrangement, and indeed this has already been done. Again, the 5-pulse group consists of 0's of null energy level, and of 1's of finite energy level; a simple circuit change will make these symmetrical about the null axis. Finally a very slow wire drive with recording head must be provided, so that the electrical pulses can be placed upon the wire as typing is carried on; by trivial circuits this can be made to provide marker pulses automatically between keyed characters (see VII.43) and at the end of word groups of characters.

VII.33 Practical Operation of Rudimentary Type 19 Transcriber.

The operating procedure will then be as follows: The operator reads from the manuscript and types, perforating a tape and printing a page. No magnetic recording occurs as yet. She can now proof-read the page against the manuscript herself or with another operator, or she can re-set the page to the point of initiating the run and verify (as indicated below). The perforated tape is now fed back through the type 19 set, simultaneously recording on the magnetic wire and re-printing over the original characters on the typed page. Proof reading may now be accomplished between the over-typed page and the manuscript, using one or two readers. If two proof readers are used, the one reading the typed-over page should recite, since this will require a decision as to each printed character and so indicate uncertainties due to

discrepancy as found; the process must be repeated until the result is found to check; this may make it advisable to carry out the process in shorter runs, perhaps even at one line at a time.

Another scheme would be to have the operator type every word twice, meanwhile throwing a switch between words to reverse the polarity assigned to 0 and 1, or have two operators type each word into a given perforated tape, in reverse polarity. When the magnetic tape produced by this process is fed into the computer proper, each word can be erased by cancellation with the following word, in case of correct operation; whereas any error will fail to clear the M_1 register S-R so that error can be detected electronically.

VII.34 Crude Overall Checking and Error Correction

In addition to the described process of error checking while generating the input magnetic record, a crude but reliable overall check can be obtained by feeding (a) the wire eventually produced by the input transcribing operation (VII.33) or (b) a wire produced by running wire (a) into the main instrument, recording it in the Selectron memory and then immediately reading it out of the Selectron memory on the output transcriber, thus producing a new wire (b) - a check can be obtained by feeding either of the wires so produced back through another transcriber unit of the same type and verifying by proof-reading the printed page or by re-transmitting the new perforated tape.

VII.4 A MORE REFINED KEYBOARD-TO-RIBBON TRANSCRIBER.

Consider first the transcription from manuscript to keyboard carried out by the operator. The original data is not word-grouped and is presumably of a wholly foreign sort which may be assumed to have no interaction on the operator. Suppose the operator to be effecting a complicated trans-

formation when reading from manuscript and pushing down keys. Assume this transformation will have a high probability of completely random errors and practically no after effects (or memory) for code sequences of length forty or more. In this case each operator⁻¹⁰⁷ of transcribing a line of (say 72) characters from manuscript to keyboard will be independent, and no scheme of N checking cycles can give better assurance of operator reliability than N repetitions of the transformation process. We may therefore elect to have this operator "key-in" the same line twice, referring each time to original manuscript; what was typed last time being obscured by a (removable) shutter.

In this case it would be proposed to check the second transcription against the first before releasing any of the continuous wire record for "publication". This check is to be "positively affirmative" and to be from re-read output (placed on the wire by the first transcription) done by exactly the same motion and type of apparatus later to be read the wire when fed into the computing machine proper.

VII.41 Modifications to Type 19 Teletype Set.

To accomplish this, modifications of the type 19 machine would be essentially as follows: The final magnetic recording wire enters at one side of the machine, executed a single loop within the machine, and leaves by the opposite side. This wire is at all times held firmly stationary by two clamps except during carriage return after verification, at which time it is concurrently advanced by approximately the length of the loop, and then resecured. Within this loop rotates a magnetic recording-or-reading head, at speed comparable to that of the reading-in-rate of the wire when fed to the computing machine proper. Associated with this rotating head is a commutator which

preserves the locations on the loop of wire where characters may be stored. Means is provided for advancing the active commutation segments with each key action; this means it must complete a cycle of (say 72) advances also it will not check and permit carriage return on the verification cycle. ^{ELSE} We are working on detailed proposals on how these features may be designed.

VII.42 Practical Operating Procedure.

The modus operandi would then be as follows: The end of a wire is fed into the machine (wire need not be erased but may contain an old message). The operator types the first or "set up" line of the code, sending from original manuscript. The head is rotating in the stationary loop; between characters or before each line the head applies an erasing signal and for each character typed applies a strong enough signal to reverse whatever may already be on the wire at that point. It inscribes a coded sequence of four binary characters for each key-stroke, advancing around the loop in sequence. Meanwhile, printing occurs but no tape is perforated. At completion of the line (say 72 spaces) the carriage automatically returns and the typed line snaps out of sight behind the viewing window. Now an amplifier is applied to the head and the message read off, comparing each group of four characters with those currently being typed in by the operator (who refers again to the original manuscript). Upon coincidence of each character, tape is perforated and the process advanced. Non-coincidence locks the keyboard and issues a signal, no tape being perforated (and no electrical pulses issued to any optional relay stations). Upon this event the operator may lift the shutter and look at the type, and also refer to the original manuscript to see wherein the error lies. Then either the correct key in the second transcription may be punched and the checking process continued throughout the line, or the

first transcription (or part) erased by the ever-spinning head, and new characters inserted. In either case the whole or part line may be re-checked as many times as desired before releasing the captured loop of wire.

VII.43 Checking Efficiency and Risk Level Attainable.

The overall risk of this system appears to us to be quite low, and while an accurate appraisal of the risk level must await the detailed design of the system described, there appears to be at present no reason for attempting to push schematic planning in this direction beyond this proposal.

VII.44 Speed and Convenience of Operation.

The speed of operation of this system is half that of a normal Type 19 teletype; this restriction could very likely be removed and full speed obtained by providing two keyboards and two operators, one typing the first, and the other typing the second transcription of each line; both operators working concurrently but out-of-step by one line. The convenience of operation would appear to be near maximum since checking and correction is nearly immediate, with no intervening shift of records.

VII.5 A WORKABLE LOW-RISK RIBBON INTERPRETING AND INDEX SCHEME.

In order to carry out the indexing and checking principles indicated in VII.1 - VII.18, an indexing and interpreting scheme for M_2 has been developed and partially constructed. This scheme, while not ideal, appears to promise fairly low risk in accomplishing the indexing and interpreting operation, and ties in well with other practical considerations which must be met in the first design of the machine. The scheme will certainly be simplified and improved as time and experience indicate.

VII.51 General Capabilities.

The indexer-interpreter is capable of

- 1) Indexing by counting words from the beginning of the data run, under quite varied conditions.
- 2) Interpreting the characters in the words and signalling acceptance or rejection according to whether certain checks are fulfilled.

In the design of this component, first priority is given the first of these functions, that of indexing or keeping track of place in the data; which is "sine qua non". Secondary emphasis is given the interpreting function; that is, the acceptance or rejection of words on the basis of certain tests.

Further, the component is designed to carry out these operations throughout a wide range of speeds, namely it can operate

- 3) At speeds as low as the pickup head and amplifier can be effective (in fact, at manual switching rates).
- 4) At speeds as high as the wire and head can be operated (perhaps 100,000 pulses per second).
- 5) In either direction of wire travel and marker sequence.

The component will also count words correctly (assign index number) and signal interpretation errors in the presence of many varieties of faulty reading performance. It will, for example carry out its first-priority duty of indexing words, and its second priority duty of signalling errors when:

- 6) Any number of consecutive word pulses from 1 to 22, located anywhere in a given word, are totally missing; including the word-end group.
- 7) Any individual marker pulse is received with incorrect sign.
- 8) Any individual pulse is omitted in the word.

The component is not, in general, able to contend with various coincidental combinations of two or more errors.

Beyond this, the component is able to operate under both manual and automatic control, and to feed data into a shifting register properly with either direction of wire feed.

VII.52 Coding and Marker System Used.

To conform with the modified Type 19 teletype units comprising T_1 and T_2 (VII.3 - VII.34) and with the principles of VII.1 - VII.12, the 40 binary digit data entries are coded into ten groups of four (which in the rudimentary machine can be ten coded decimal characters) each being prefixed with a negative polarity "character marking" pulse, and the entire entry being suffixed by a sequence of five positive pulses. Thus 55 pulses constitute a word, which appears preceded by a- and followed by at least five positives when running in one direction, and opposite when running in the opposite direction.

VII.53 Adaptability to the Type 19 Teletype.

This arrangement is adaptable to the type 19 teletype without appreciable modification of that unit (see VII.30 - VII.44).

VII.54 Effects on packing density, erasure, reversability.

The efficiency of this marker-indexed code is roughly 75 percent of the optimum packing density (no spaces and no markers used). The problem of erasure is actually facilitated since markers introduce spaces between words and characters, and since interpretation is possible, even if one marker is lost during erasure.

The highly flexible word-indexing system incorporated in this component greatly relaxes the difficulty of controlling the motion of M_2

during reversal. Specifically, it has been indicated that the word index numbers will be correctly assigned even though nearly half a word is missing; if, for example, reversal takes place due to constant deceleration and acceleration in the opposite direction, it may be of interest to inquire what rates of acceleration are necessary in order that the length of ribbon traversed at sub-threshold velocities will contain less than half a word. If 200 pulses are packed per inch (twice as dense as we consider at present) and if the minimum reading speed is 1 foot/second (about ten times what we consider threshold) then 3.7 g will accelerate through zero so that only 20 pulses are missed; and certainly three or four times this acceleration could be tolerated.

VII.55 Definition of "Correct Operation" of the system.

The system is designed to count word groups correctly under the conditions and in the face of errors as indicated above; it is also designed to signal certain reading faults correctly whenever they exist and word count is accomplished. It is designed to place these words in the shifting register in proper order whenever no such fault is signalled, and to signal their acceptability. It is designed to identify certain types of error by expressly diagnostic signal. When these duties are properly carried out, the system may be considered to be operating correctly.

VII.56 Types of Faults Disclosed in Correct Operation.

The indexer-interpreter component will indicate, when conditions (1-9 SS VII.51) permit word indexing, all errors in a word due to

- 1) Omission of minus "character-marker" pulses
- 2) Reversal of polarity of minus "character-marker" pulses
- 3) Omission of any data pulse in a word.

4) Omission of word-end markers.

Clearly the absence of word-ok-pulse can be used to inhibit or re-rout the transfer of a given erroneous word, by properly tying in this signal with the control of the machine; and to arrest operations or start re-reading procedures as desired.

VII.57 Types of Faults Resulting in System Malfunction.

Clearly the word interpretation function cannot be carried out in any meaningful fashion unless the word index is maintained, so that the conditions under which count is lost are of primary interest. word count may be lost when

- 1) More than 23 pulses in a word are omitted.
- 2) Two marker pulses separated by 25 or more pulses but within one word, are omitted.

If words be properly indexed and counted, the "error" signal will fail to disclose departure from proper grouping (of 10 groups of 4 data pulses each) only when an element or component of the interpreter system fails.

VII.6 DESIGN AND CONSTRUCTION OF RIBBON INTERPRETER AND INDEXER.

Turning now to the design of this unit, Figure 17 indicates schematically the entire process of indexing and interpreting words received serially from the wire-recording head. Essentially, the scheme is to receive the words together with markers, check that the data is grouped in 4-pulse characters; check that preceding each 4-group is a minus pulse; check that there are ten minus pulses and forty data pulses in each word, check that these are followed by at least five consecutive, positive word-and marker pulses, check that the next word starts with a minus; - if all these

conditions are met, delete all marker pulses and place word in shifting register in correct orientation, count it and signal acceptance.

The input lines to this system are three:-

Pulses from the wire

Initiating switch: Proceed Forward (F), Proceed Backward (B)

Automatic Control: Restart Forward (F), Restart Backward (B)

The output lines are four:

Register and stage "set+or set - "

Register shift left or right (wire direction)

Word count signal

Word OK signal.

The basic components of the system are an input pulse separator, a 5-stage chain counter, a 5-stage ring counter, a 12-stage chain counter, the shifting register (part of the arithmetic organ) and various binary counters and gates among which are "early word", "word end", etc. The entire arrangement will be built on three chassis units indicated as I, II, and III. Various accessory features provided for testing purposes are enclosed in dotted lines.

To discuss this schematic diagram in detail, certain symbols require definition:



GATE (Unilateral) Normally Blocked. During activation of "release" line, signal may pass from left to right.



GATE (Unilateral) Normally Passing. During activation of "release" line may not pass from left to right.

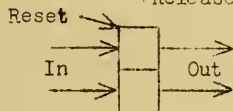

TOGGLE (Flip-flop) Coding 0-1 or 1-0. Placed on input leads produces corresponding static state at two output leads.

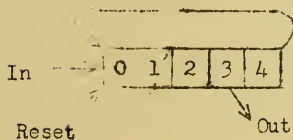

RING COUNTER

Steps one cell for each pulse received on input; reset for pulse at reset lead at any time; has end-around carry; cell output states are static.

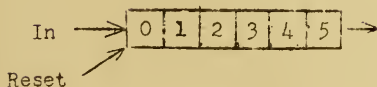

CHAIN

Same as ring except unaffected by input after last position, unless reset.



BUFFER AMPLIFIER

Unilateral transmitter; a gate which is always passing.



Neon lamp indicator for manual tests.

Briefly, the operation of the system is as follows:

- 1) Input pulses (data with markers) passes into the separator, are re-shaped, and standard unidirectional signals are emitted on three channels, one corresponding to each algebraic sign, and one to both.
- 2) The 5 stage chain is entered; positive sign groups are examined, re-setting with each negative so that this counter fills only for the 5 plus pulses corresponding to word end.
- 3) Concurrently the 5-stage ring and 12 stage chain are entered, and signals arrive at the shifting register.
- 4) The 5-stage ring excludes every fifth pulse, checks it for sign, gating OK only when it is minus. Failure of this gate inhibits the word "OK" signal.
- 5) The character-groups of 4, devoid of minus markers, are thus passed into the shifting register.
- 6) Meanwhile the 12 stage chain counts total number of pulses and send outs a signal at number 56 regardless of polarities of pulses counted.
- 7) Word-end may have been signalled earlier, elsewhere, as by (a) accidental omission of a minus marker earlier in the word, thus activating 2), or (b) occasioned at pulse 51 due to the last character in the word containing unbroken positives thus advancing 2). Recall that the word end, and word-marker group are not separated by a negative pulse.

- 8) hence the word count signal is caused to depend upon arrival of the leading minus in the next word. (When wire feeds backward this inconvenience vanishes.)
- 9) Prematures of type 7)(a) are eliminated by "early" gate system frustrating (2) for accidental negative pulse omissions in the first half of the word; this prevents any double word count due to this cause.
- 10) Once word count is allowed, all resets operate and process repeats. Except for the shifting register, complete circuit diagrams have been constructed, and are shown in Figure 18, (which is regrettably illegible in this reproduction).

VII.61 Pulse Separator, Word End Chain Counter: Chassis I,

Figure 19 gives in more legible form the complete wiring diagram of chassis I which has been constructed (see Figure 20) and tested (see Figure 21) and found to operate entirely as desired.

This chassis consists of the pulse separator and word end counter. The top oscillogram (A) of Figure 21 shows 9 pulses of a word created by the word generator of section IV.5; these are spaced at 10^{-5} sec. and are applied to the input of Chassis I. In (B) the word and pulse generated by Chassis I is shown; C shows the output of the plus pulse channel, D the minus pulse channel, and E the joint output channel. F shows the word end pulse alone.

Note that all pulse outputs from Chassis I are reshaped; that is, are sharp and narrow regardless of input shape.

Tests on Chassis I have indicated the desired operation is successfully attained at repetition rates from those of manual switching to

C - 3 - 1002 - P (SK)
INPUT DISTRIBUTOR - Schematic -
Chassis II
("INDEXER")

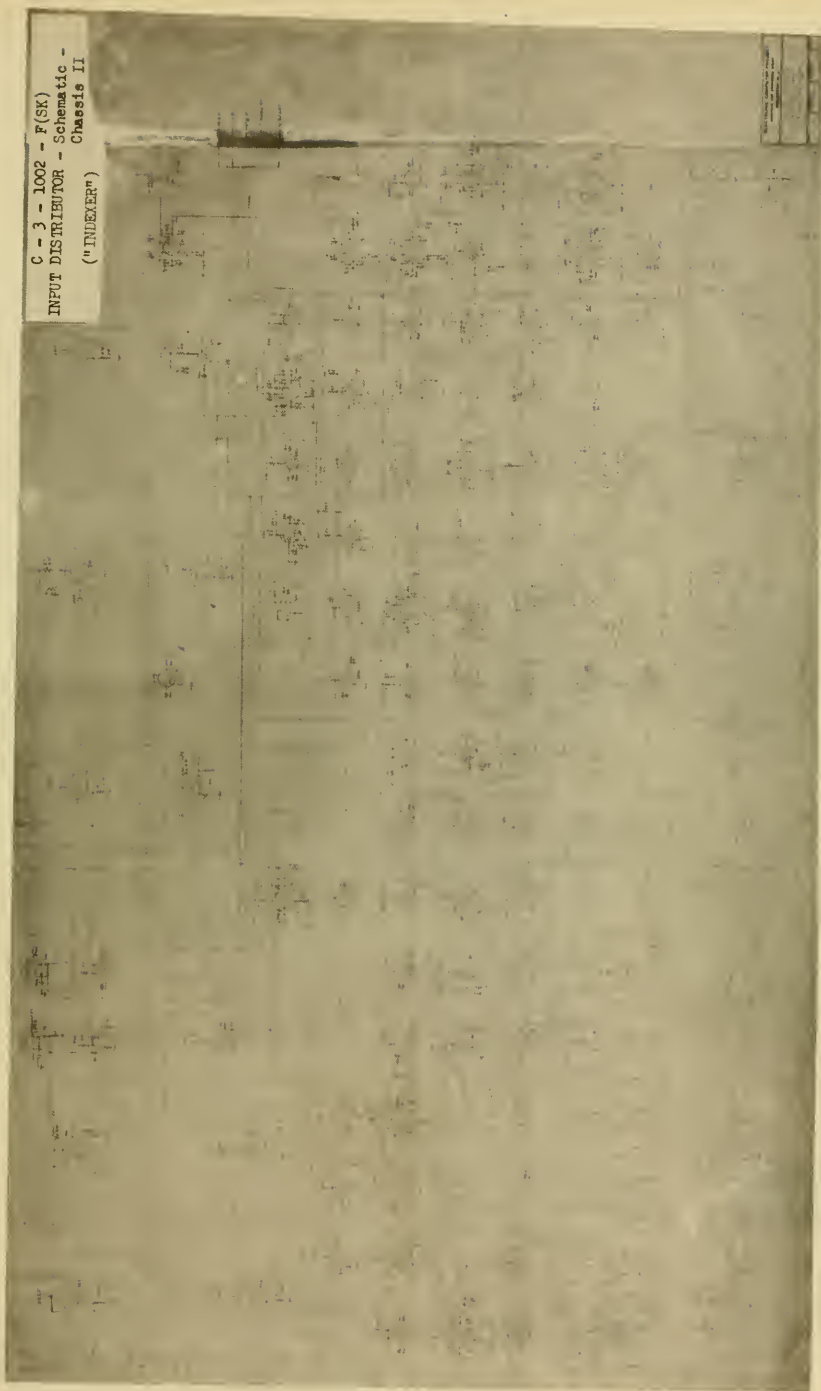

Figure 18
Circuit diagram of Indexer-Interpreter

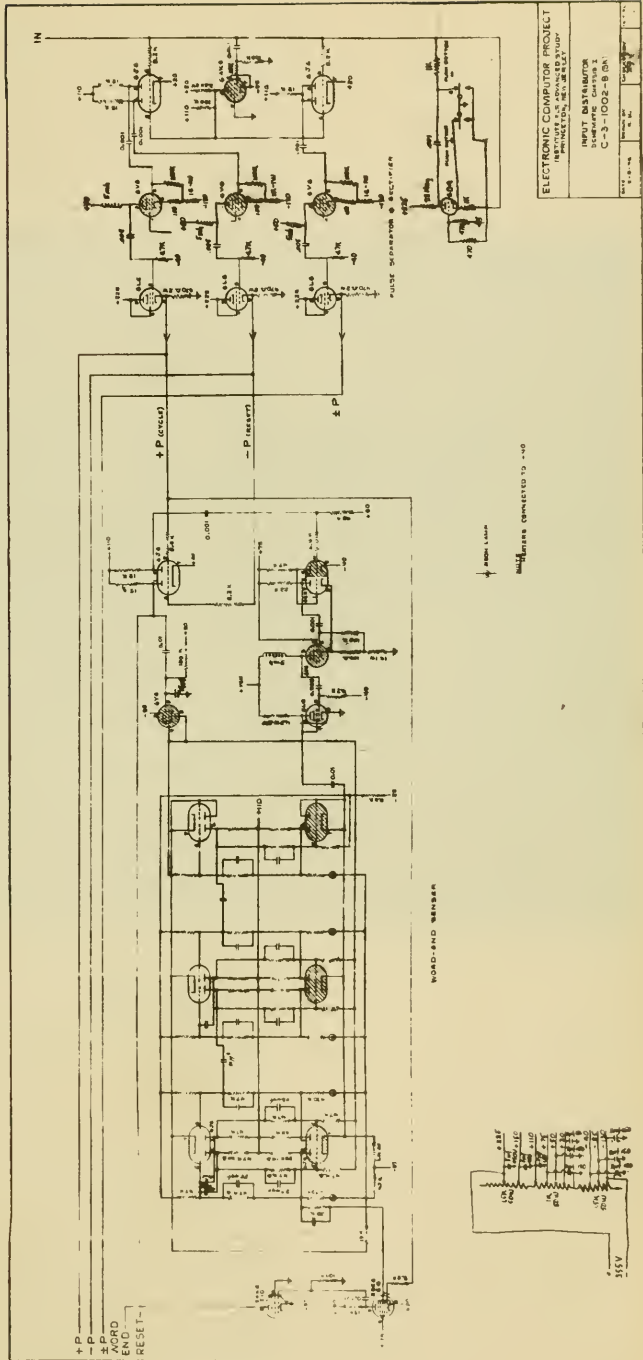

Figure 19

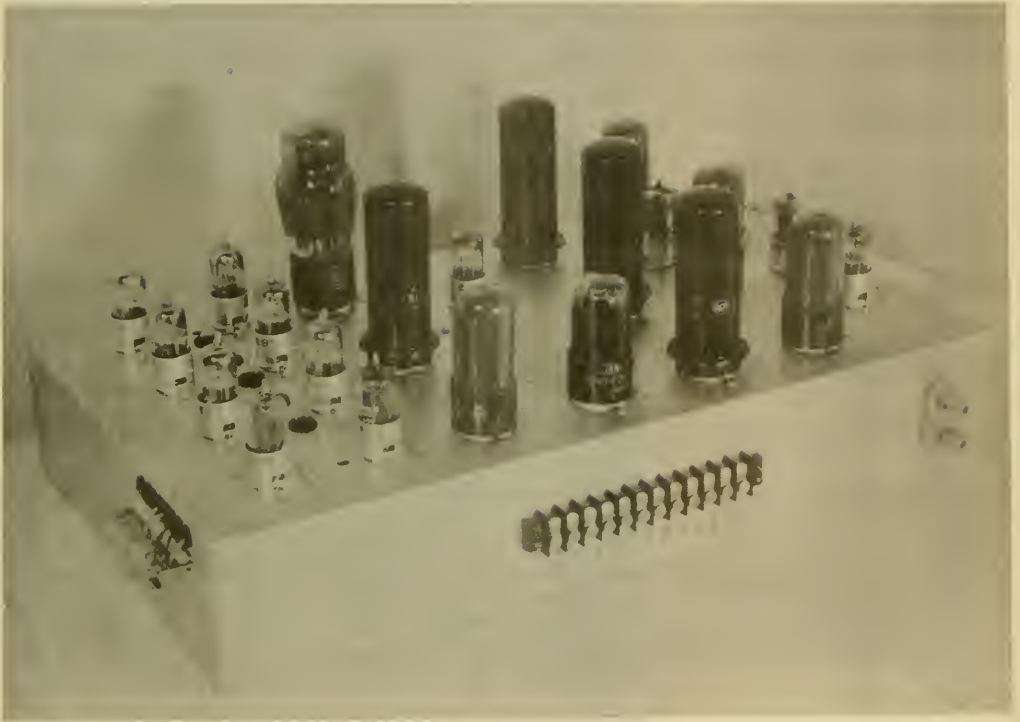
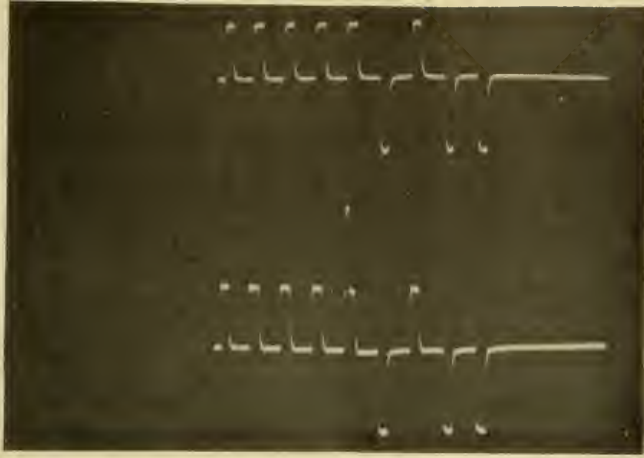
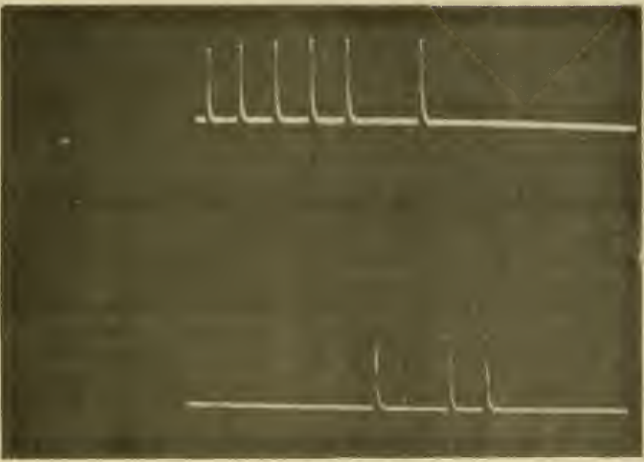

Figure 20
Input Distributor - Chassis 1



A. Input Pulse Group



B. Input Pulse Group -
Word End Pulse
Superimposed

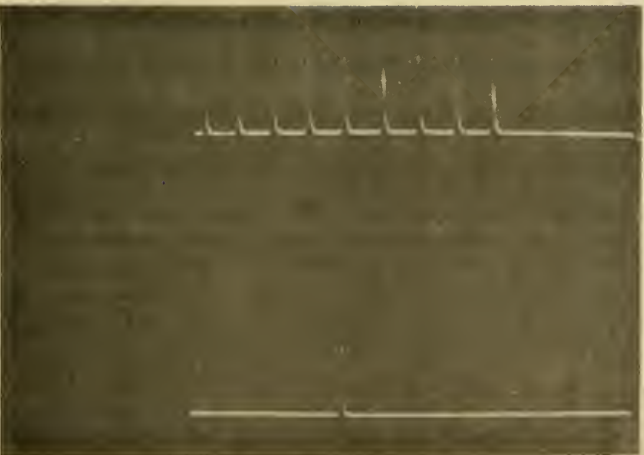

C. Plus-Pulse Output

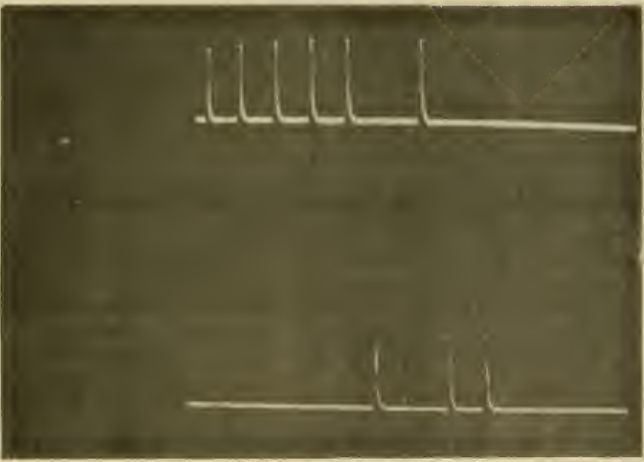

D. Minus-Pulse Output

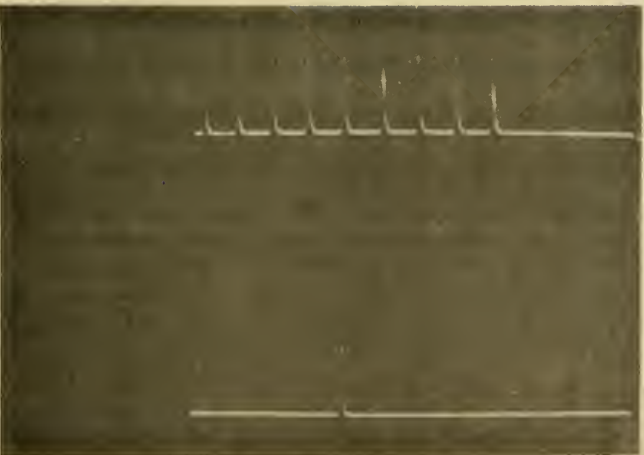

E. Plus-Minus Pulse Output

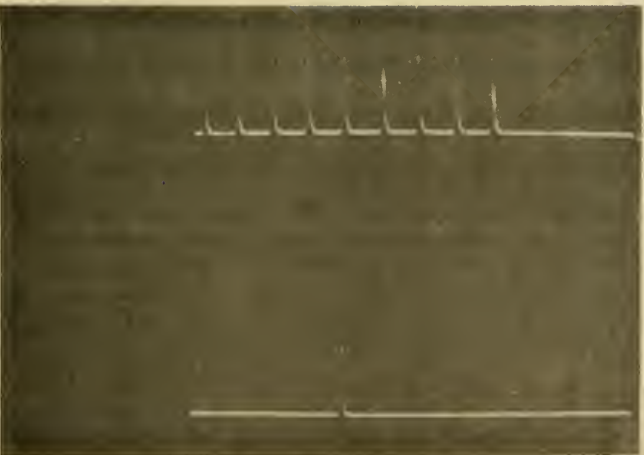

F. Word-End Pulse Output

Figure 21
Oscillograms of Chassis 1 of Input Distributor

10^5 pulses per second. It does, however, require pulses of moderately steep wavefront. Further work is in progress to relax this requirement.

VII.62 Controls, Minus Marker, Totals Counter, Early Circuit, Chassis II.

This chassis is in process of construction, and will be finished within the next few weeks.

VII.63 Shifting Register and Associated Gates: Chassis III.

This chassis is being developed in connection with the program on the Arithmetic Organ, and progress is described in Sections 9 and 10.

VII.7 Low Risk Scheme for Printing from Magnetic Ribbon.

The final terminal component requiring discussion is that enabling magnetized wire to be transcribed into typed form, so that the output from the machine can be read with confidence by the operator. Many schemes for accomplishing this were considered, involving more or less complete checking features, but as in the case of input transcription no method appeared presently practical for automatic over-all feedback checking of the type characters against the ribbon record other than by human operator.

VII.71 Adaptability to Type 19 teletype.

In view of this unsurmounted technological obstacle it was decided that a very simple printing scheme would give all desirable checking and reliability. This scheme is, in brief, to arrange two entirely separate output wire interpreters and printing typewriters so as to print a single result-paper, the two being arranged so that one unit prints a line and the other reprints the same line, almost (or even directly) on top of this same line. The two units could be arranged to operate concurrently, being staggered on the magnetic wire and printed record by one line of text. These units could be

Type 19 teletype printers suitably mounted to operate on a single paper roll.

VII.72 Verification System and Risk.

The scheme of verification would then be accomplished by human operator at no added inconvenience, assuming the two units to be independent, errors will appear as ever-typed disagreeing characters, choice between which must be made by the operator in the course of interpreting the result. Hence errors of omission by the operator, in checking, would be minimized.

VII.73 Speed and Convenience.

It would appear that this scheme would permit essentially the full speed of whatever printing unit was used, and that checking is accomplished by telescoping the operation of checking and interpreting manually. This would seem a happy minimum.

VIII. BINARY ELEMENT EXPLORATION

TEST APPARATUS

VIII.1 TECHNIQUES: DEVELOPMENT OF SPECIAL TEST APPARATUS

As has been indicated, the arithmetic organ and certain components of the control organ will be required to operate at rates on the order of a microsecond per elementary transfer. These operating speeds present new difficulties distinct from those encountered in the vicinity of tenth-megacycle rates, such as are attainable by the elements in the indexer-interpreter. It has been clear since the initiation of the project that the attainment of these higher rates would involve a program on the development of high-speed binary components, and that this in turn would involve special techniques and call for the construction of electronic test apparatus, some of which would be of familiar type, and some quite special.

VIII.2 POWER SUPPLIES

Because of the frequent need and high expense of purchased assemblies, one of the first construction programs undertaken by the group was a series of plate voltage power supplies. Building these relatively simple test units not only proved economical but served as a "break-in" project for the group.

Two types of power supplies were built, and are shown in Figure 22 and 23. The smaller unit delivers 500 volts, 75 milliamperes DC and 6.3 volts center tapped AC for cathode heaters. The unit is fused, has pilot lamp, voltmeter, 10,000 ohm output voltage potentiometer-adjustment, on-off switch, 60 cycle 110 volt cord and plug. The filter is of CLC type and the circuit is diagrammed in Figure 24. Twelve such units were built and are continually



Figure 22
500 volt, 75 ma. Power Supply



Figure 23
600 volt, 300 ma. Power Supply

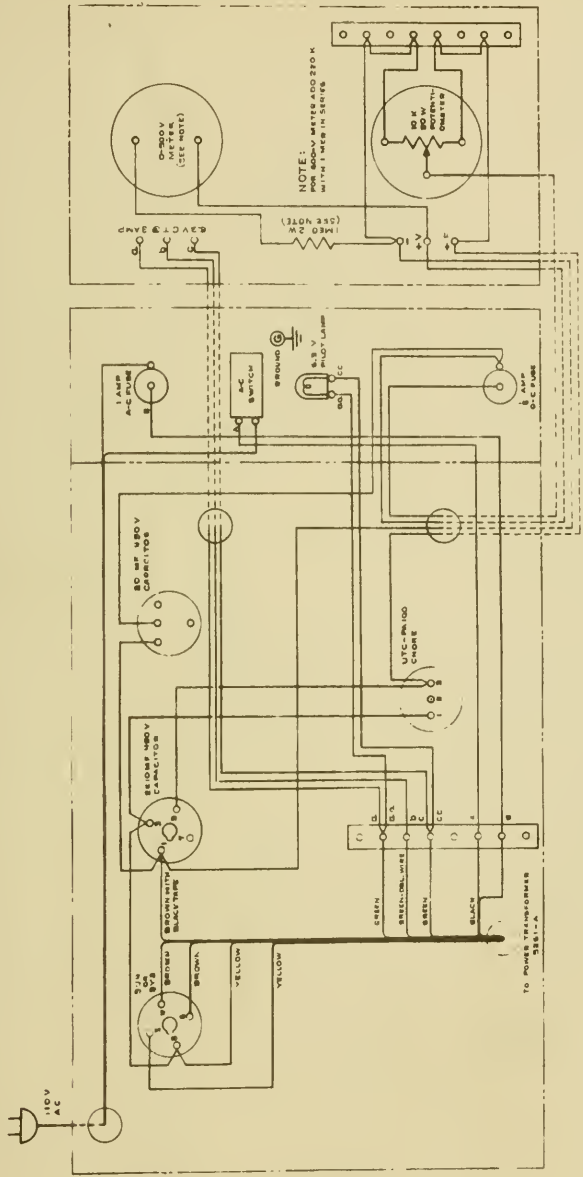

3) ORDER OF WIRING & SPEC OF LAMP PART OF UNIT.
WIRING DIAGRAM

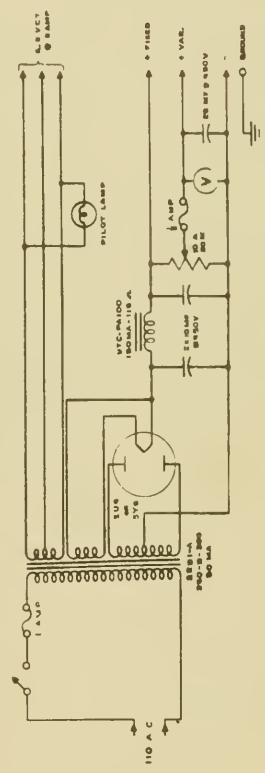

SCHEMATIC

2) SPEC OF LAMP PART OF UNIT.

ELECTRONIC COMPUTER PROJECT INSTITUTE FOR ADVANCED STUDY PRINCETON, N. J.	
SMALL SUPPLY DESIGN REVISED 4-20-60	
DATE 9-1-58	DESIGNED BY M. H.
C - 2 - 1002	

Figure 24

in demand for experimentation.

The second power supply type is larger, delivering 600 volts, 300 milliamperes and has two 6.3 volt cathode heater supplies. It also is provided with fuse, switch, pilot lamp, meter and connecting cord, but does not have voltage adjustment. This unit is shown in Figure 23 and the circuit represented by Figure 25; the filter is of LCLC type. Six units of this type were built and are in frequent use.

VIII.3 OSCILLOSCOPE AUXILIARY SWEEPS, MARKERS, TRIGGERS.

Because of the difficulty and expense of obtaining cathode-ray oscilloscope outfits suitable for microsecond pulse work, an accessory outfit was developed capable of being attached to the standard DuMont oscilloscope cabinet. This outfit is shown in Figure 26 and its accomplishments represented in Figure 27.

The unit is capable of sweeping at a rate of .3 microsecond per linear inch, and is quite linear in its time-distance relationship. Markers are provided of .1 microsecond and 1 microsecond interval and a convenient, adjustable trigger delay is also provided for the sweep.

This unit has proven quite useful in many pulse development problems.

VIII.4 OSCILLOSCOPE VOLTAGE CALIBRATORS.

Because of the need for amplification, both in binary element development and in ribbon memory development, it is convenient to have some method of calibrating amplifiers on suitable pulses rather than relying upon the constancy of their voltage gain ratios. For this purpose a pulser-calibrator was devised, as shown in Figure 28, the "square" wave pulses of known voltage plateau being shown in Figure 29 and the circuit schematic in



Figure 26
Fast Sweep, Marker, and Delayed Trigger Generator
(shown in place on oscilloscope)

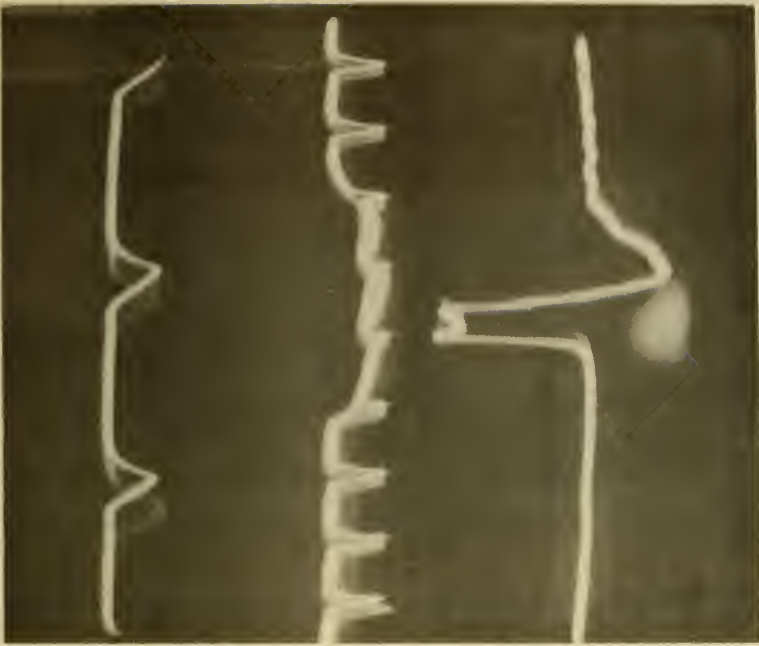

A. (Top) Short sweep and 1 us. markers.
B. (Center) Longer sweep, 1 us. and
strobe markers.
C. (Bottom) Delayed trigger pulse.

Figure 27
Oscillograms of Fast Sweep and Marker Generator



Figure 28
Voltage Calibrator

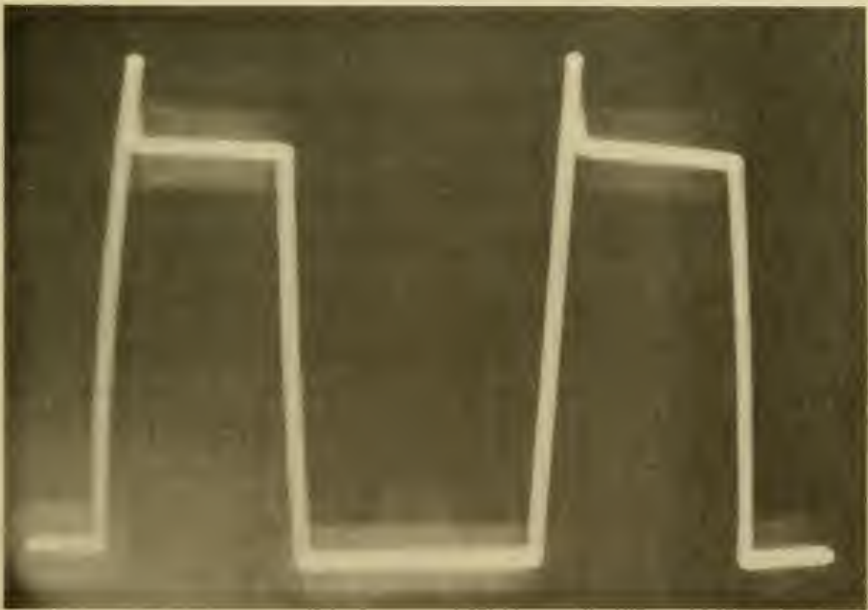
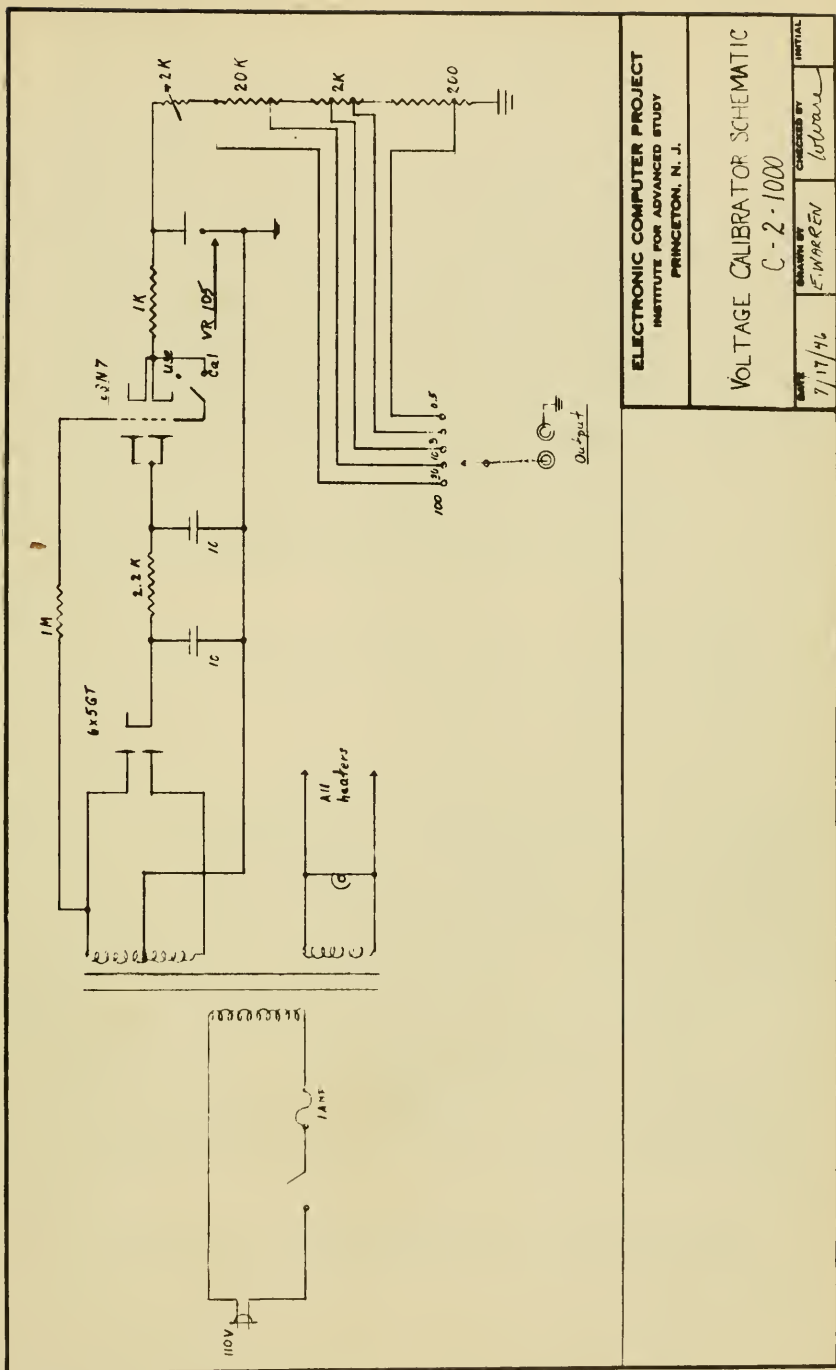

Figure 29
Voltage Calibrator Output Wave Form



ELECTRONIC COMPUTER PROJECT
 INSTITUTE FOR ADVANCED STUDY
 PRINCETON, N. J.

VOLTAGE CALIBRATOR SCHEMATIC
 C-2-1000

DATE: 7/17/46
 DRAWN BY: E. WARREN
 CHECKED BY: [Signature]
 INITIAL: [Signature]

Figure 30

Figure 30.

VIII.5 PULSE FORMING CIRCUITS.

It frequently occurs, in high speed pulse work, that a unit is desired having the ability to re-shape pulses; or rather to emit a pulse of standard height and narrow duration within a minimum delay after the arrival of an input pulse of varying character. Such circuits have been developed for radar work and elsewhere and our group had several occasions to develop high performance units of this type; for example, as included in Chassis I (Figure 19, center stages).

These pulsers will be used in the control organ and elsewhere.

VIII.6 SLIDING PULSERS:

To test repetition, reaction and recovery times of various binary elements, the need frequently arose for a device capable of omitting standard sharp pulses upon demand (finger switch) or periodically (at intervals relatively infinite compared to pulse duration) in pairs or triples, such that the interval between pairs or triples could be adjusted at will.

To accomplish this the devices pictured in Figure 31 (triple version) and in Figure 33 (quadruple version) were developed. These consist essentially of three or four gaseous discharge relaxation oscillators adjustable in relative firing time; they can produce pulses of about 100 volts peak across loads of 1000 ohms, having durations of 10, 1 and .1 microseconds, these outputs appearing on separate or common bus-bars. The units are crystal controlled and have individual adjusting (sliding) knobs for each pulse, and push-button test-pulse controls.

It is the opinion of all those who have made the sliding pulsers



Figure 31
Oscillograms

- A. Wide, narrow, medium width mixed output pulses
B. Wide, narrow, medium width mixed output pulses

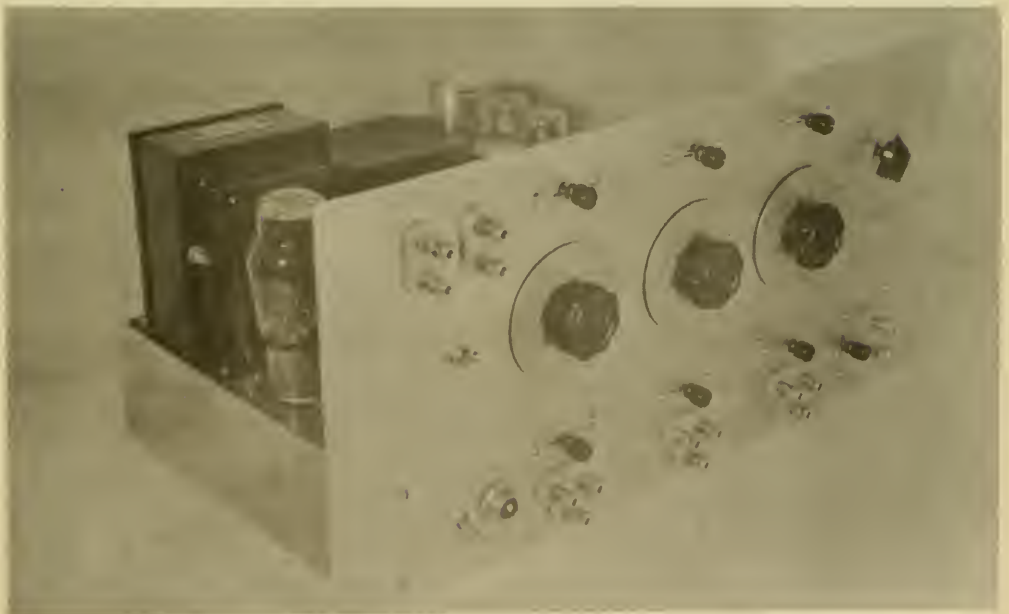

Figure 32
Sliding Pulse Generator

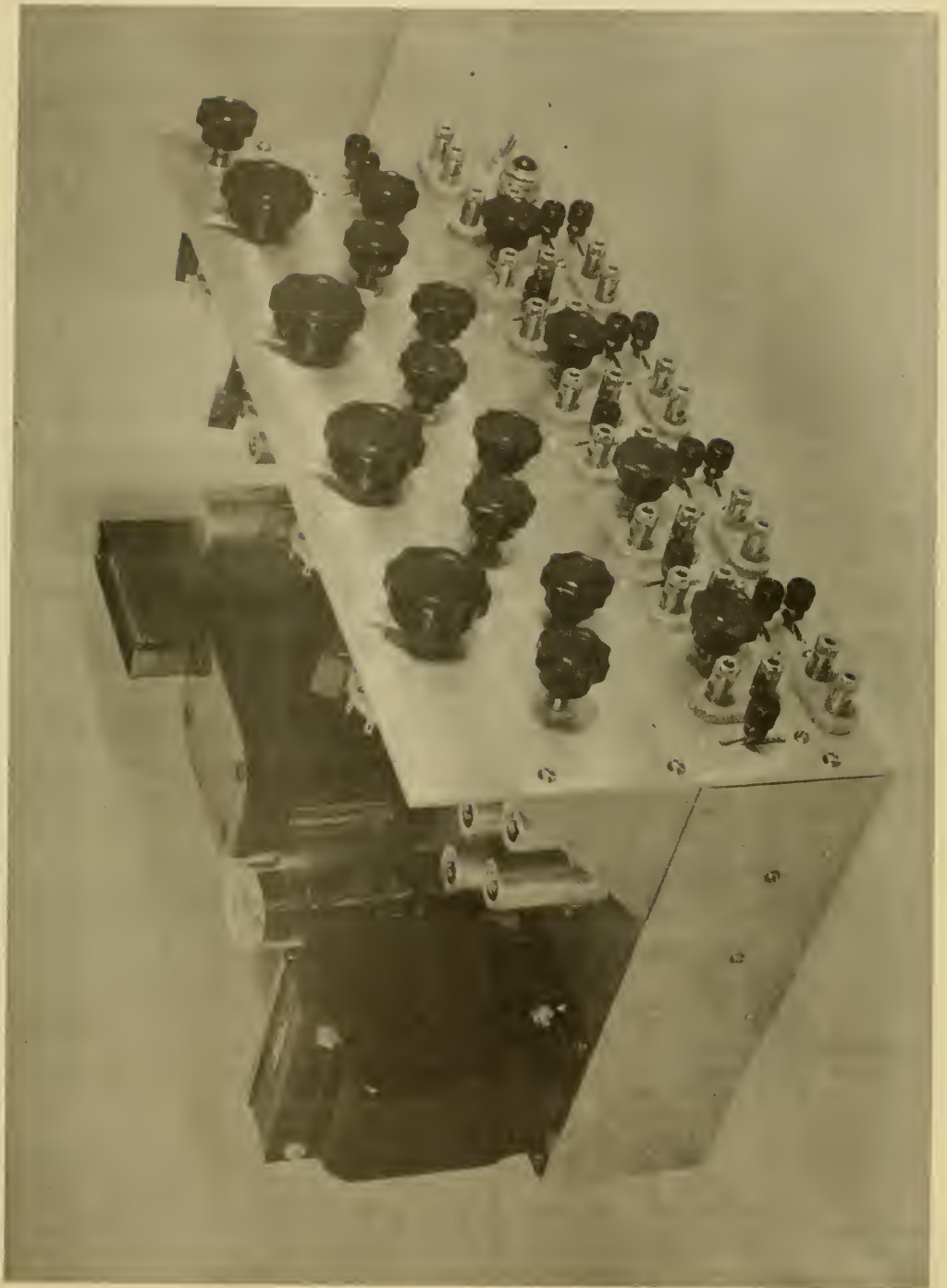

Figure 33
Sliding Pulse Generator

that they have saved many months of work in pulse testing of binary elements.

Sample oscillograms showing the performance and use of the sliding pulser are to be seen in Figure 40 where a 50B5 Eccles-Jordan Binary element is under test.

VIII.7 TRANSMISSION LINE PULSE GROUPEUR

As in the case of tests on magnetic recording media, the need arose for a device capable of producing entire coded words at megacycle rates so that tests more like those of actual word transfers could be carried out. For this purpose it might appear that a high-speed ring counter with gates could be used, driven by a megacycle (or higher frequency) oscillator, in a fashion analagous to that described in Section IV.5. However, a little reflection will indicate that this scheme will begin to break down just where most interest is attached, namely, at the threshold of operation of vacuum tube binary elements; and since such flip-flop elements make up the ring counter as well as the subject of test, other means must be found for pushing toggle elements to their limits. One answer is clearly independent sequential pulse sources as indicated in the previous section; another means is to use a pulse driven transmission line tapped and gated at points separated by a very small delay.

Such a devise may be called a pulse grouper, and is pictured in Figure 36, the circuit being indicated in Figure 37. The scheme is essentially like that of the ring-counter with gates (described in Section IV,5) except that the counter is replaced with a transmission line of about six microseconds delay, tapped at every tenth microsecond section, and provided with a gate tube to be opened or closed by manual switch, thus coding

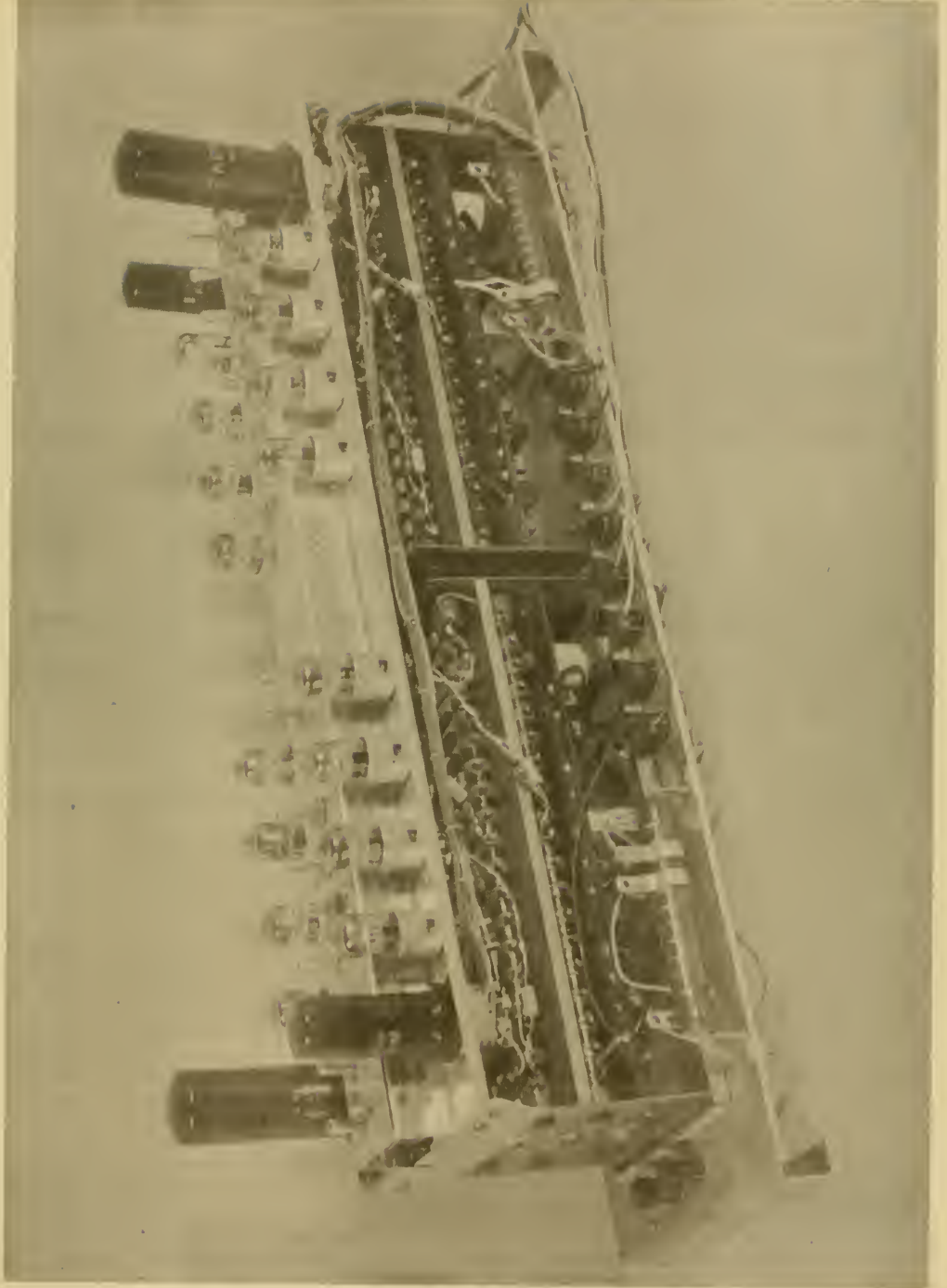

Figure 35
Pulse Grouper

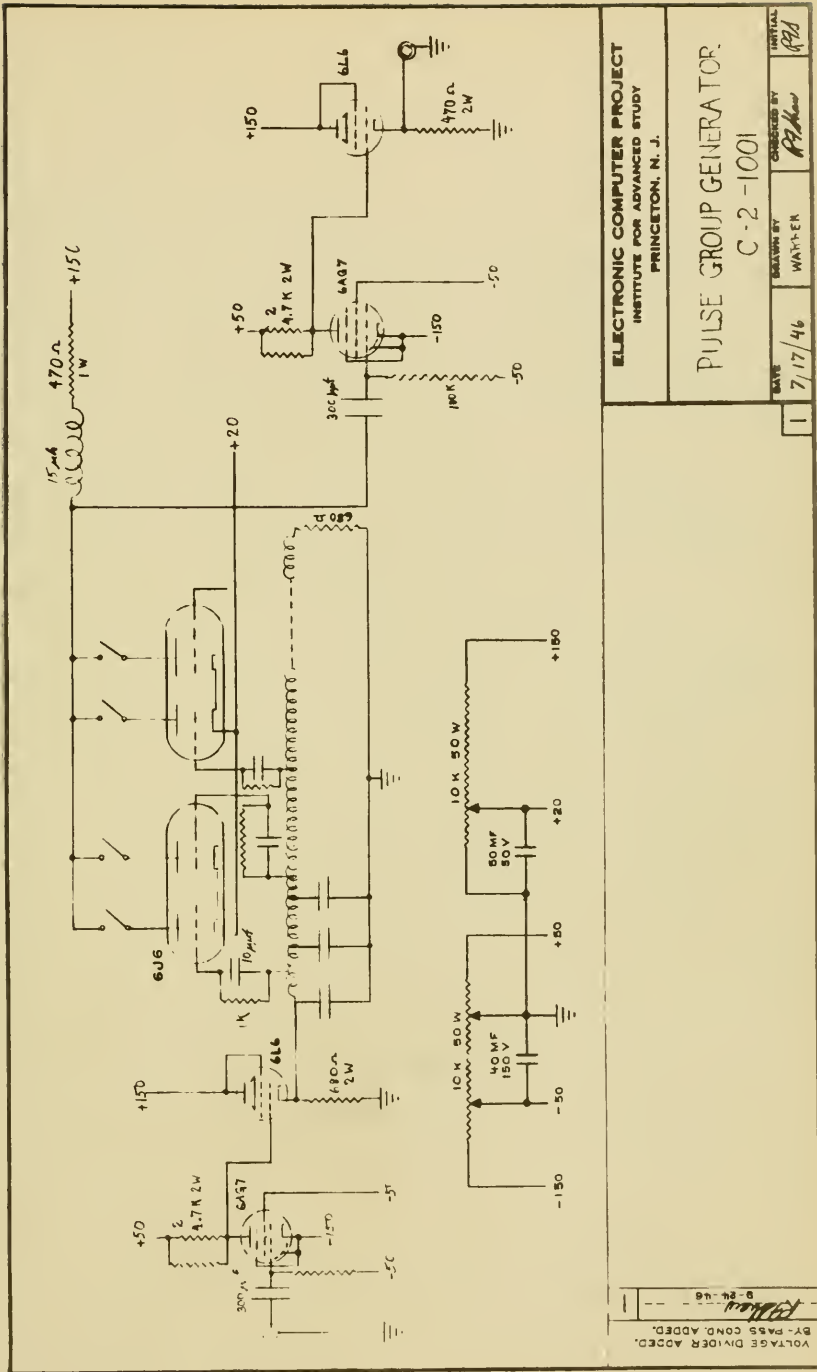

Figure 36
Pulse Grouper

ELECTRONIC COMPUTER PROJECT
INSTITUTE FOR ADVANCED STUDY
PRINCETON, N. J.

PULSE GROUP GENERATOR
C-2-1001

DATE: 7/17/46
DRAWN BY: WATYER
CHECKED BY: P. Howe
INITIAL: PPH

VOLTAGE DIVIDER ADDED.
BY: P. Howe
9-24-46

the desired word.

VIII.8 VACUUM-TUBE LIFE AND FATIGUE TESTER.

Since the beginning of the development work of this project there has been an inclination to favor the use of miniature tube types. This preference exists partly for reasons of personal taste, partly because these tubes are in current favor, and especially because the miniatures are compact, of high performance and are available in convenient types.

However, because they are of very recent design there remained a vague fear in the minds of some of our group that perhaps extensive use would later disclose inferior life statistics compared to older types.

Quite clearly a statistical test adequate to appraise the life performance characteristics of miniature tubes would not be a practical project for our group to undertake, since the failure distribution is a function of many variables not known to be independent nor to be related in a specified manner; further the essential parameter in tube life is certainly time, over a space of many months or even years. The failure probabilities sought are certainly very small, implying the need for very large samples; furthermore failure should be examined in a qualitative sense, and not merely as an attribute.

However, it was considered essential to know whether such miniature tubes as the 6J6 have radically inferior lives compared to other types, to an extent rendering their use in design a major blunder; and accordingly a crude life-test set up was devised and operated to get some sort of a statistical bound on their reliability.

The life-test apparatus consisted of four banks of 6J6 tubes, 20 in each bank, making a total of 80 tubes or 160 triode sections. The banks

were oriented up, down, and in the two horizontal positions, (cathode edge-wise and cathode flat). Each bank was operated at normal ratings as a direct coupled amplifier of 20 stages, the final stage being fed back into the input stage so that each whole amplifier system oscillated in multi-vibrator fashion which, when viewed in the cathode ray oscilloscope, enabled a pulse reversal to be seen corresponding to each triode stage; hence the qualitative performance of each stage could be examined without individual probing.

Believing that the most common cause of tube failure would be cathode heater failures due to mechanical stress or fatigue, the entire affair was mounted on an aluminum plate and supported on Lord shear mounts, and vibrated by means of an eccentrically weighted electric motor fastened perpendicular to the plane of the plate. This small motor produced a displacement of about $1/16$ inch and an acceleration corresponding to slightly less than one gravity unit.

The tubes were operated for about 3000 hours and gave very satisfactory life indications; a total of six failed, four within the first few hours, one about 3 days and one after 10 days. There were four heater failures, one grid short and one seal failure. When time permits a few statistical estimates will be made from this data.

The arrangement is pictured in Figure 37; the circuit indicated in Figure 38.



Figure 38
Schematic Diagram of Ring Oscillator of Tube Life Test

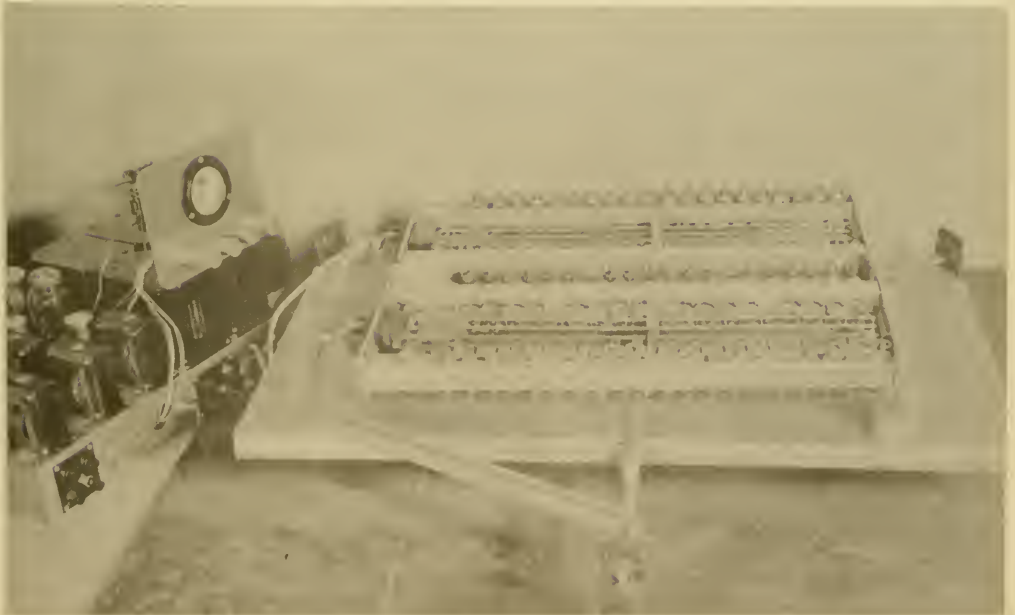

Figure 37
Vibration Table and Tube Life Test

IX. BINARY ELEMENT PERFORMANCE STUDIES

IX.1 ECCLES-JORDAN TOGGLE CIRCUITS; CRITERIA.

The conventional Eccles-Jordan toggle circuit consists of two tubes having at least three elements; cathodes are connected directly to a zero potential level; anodes are connected each through a load resistance to a positive high voltage source; grids are connected each through a bias resistor to a negative voltage. In addition there is a "transposition" link consisting of a parallel R-C pair between the plate of each tube and the grid of the alternative tube. (See sketch (1).)

The time-stable voltage states of this circuit are determined by the resistor values, supply potentials and tube conductances involved. The transition phenomena is determined by these parameters and by the transposition capacitors; also by the electrode and circuit parasitic capacitances and by the nature and point of application of the shifting pulse.

The criterion of performance of such a circuit is primarily the speed with which it changes state; more particularly, the highest repetition rate at which pulses can be applied so that the device acts a binary counter. This maximum repetition rate occurs at a particular pulse width and amplitude, all variations of pulse other than this optimum tending to reduce the rate.

IX.1.1' Symmetrical Pulsing.

It may be remarked that the Eccles-Jordan circuit is normally pulsed at a point symmetrical in the circuit structure, such as at any of the supply leads. The order to "change" is a signal without sign of direction; reliance is placed upon the circuit to remember its pre-change state during transition.

This phenomena of circuit memory during transition, lasting through the point of indecision, can easily be seen by considering the cathode to be suddenly pulsed positive and examining the sequence of events that follow. Pulsing the cathode is, of course, not a special case since an equivalent result can be obtained at grids or plates.

The voltage drop across the two transposition networks prior to pulsing will of course be quite different. The voltage drop across the network connecting the "on" plate to the "off" grid will be quite low compared to the voltage drop across the other network, due to the fact that the plates swing further than the grids. Call these voltages across the transpose condensers "Momentarily Low" and "Momentarily High" respectively.

Now consider the cathodes to be pulsed positive, and to dwell; this upswing should be of very steep wave front. The positive grid will suddenly find itself negative relative to the cathode; the negative grid being already beyond cutoff will notice no change (except that due to capacitative coupling with the cathode; if the transpose capacitance be large compared to C_{gc} and the plate load resistance moderately low. This effect will be small, symmetrical and equivalent to a small loss in initiating pulse). The "on" plate will almost immediately start toward the positive bus potential; (both plates will have a slight capacitative shove in this direction) - notice particularly that the pulse dwell (duration above a certain voltage level) and the transpose circuit time constant must both outlast the next few phases of the operation. Returning to the "on" plate, it travels very rapidly to the positive bus pulling the negative grid coupled at "momentarily low" voltage drop with it, until it goes more positive than the positive-dwelling cathode, at which the "off" tube is

turned full "on". Now the "off" tube plate swings down, showing the "on" grid (at the end of the momentarily high voltage drop circuit) way negative, from which it gradually returns. During the last operation the initiating pulse returns to standby level.

It is seen that the balance of time-constants for effective performance is quite involved and apt to be critical. The pulse front must be steep, the dwell longer than both both plate reaction times in succession, and the transpose circuits also of about this same magnitude. Shortening either pulse or transpose-time-constants tends to leave the circuit "stranded" near the point of indecision, from which it recovers slowly due to the low value of the unbalance (or different current). Lengthening these times causes overlap at high repetition rates, so that the unit again tends to operate in the region of indecision. Pulsing symmetrically on grids or plates complicated the analysis but does not change the basic picture.

IX.12 Performance of 6J6

Circuits of this type are nevertheless quite fast, simple and reliable. Tests were made using 6J6 twin triode miniature tubes, and repetition rates higher than a microsecond were readily achieved, operating the tubes well below ratings. Attempts to further increase speed by juggling resistances, capacitances, putting inductance (self and mutual) in various places, pulsing in various ways, ^{met} not with small success - a questionable gain of a few tenths microsecond being occasionally achieved.

IX.13 The Case for Triodes.

It may be well to inquire what advantages the 6J6 twin triode may have over other tubes; in particular, over a twin pentode. In brief, the

justifications are that the triode has two less elements, is therefore structurally simpler and probably more reliable, requires fewer connections and should be capable of accomplishing what is desired with safe margin.

The pentode superior performance may well be due to geometry subject to greater variation. If this is used to full advantage in design, it is thought that reliability may suffer.

IX.14 Screen Pulsing.

Clearly the use of pentodes or tetrodes in an Eccles-Jordan circuit affords another terminal by manipulation of which exchange may be effected; pulsing the screen has the advantage of fairly sensitive control without the disadvantage of charge placed on the transposition condensers due directly to the pulse, as is the case when pulsing control grids.

IX.15 Performance of 50B5 Screen Pulsed.

The 50B5 is a power pentode of remarkable conductance. A standard flip-flop circuit was constructed using two tubes of this type, and screen pulsed. The result gave extremely high speed performance, as evidenced by Figure 39. In Fig. 39A the two triggering pulses from the "sliding pulses" are shown; in B the binary transition in a plate circuit may be seen. It should be noted that the rise time is very short - on the order of one or two tenths microsecond. Figure 39C shows nearly coincident trigger pulses, and D indicates a resolution limit for the binary stage which is certainly in the neighborhood of one-tenth microsecond.

While this development is considered to be encouraging and very illuminating, it is not considered desirable to build 40-binary stage arithmetic components using pairs of 50B5 tubes because of the enormous power and space

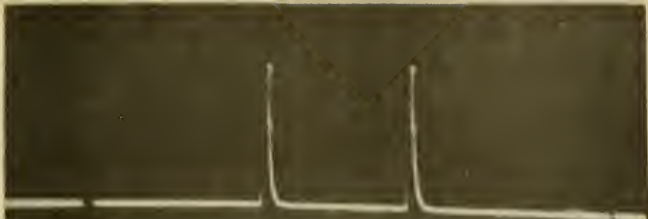

A. Triggering Pulses
(Markers are 12 us.
apart)

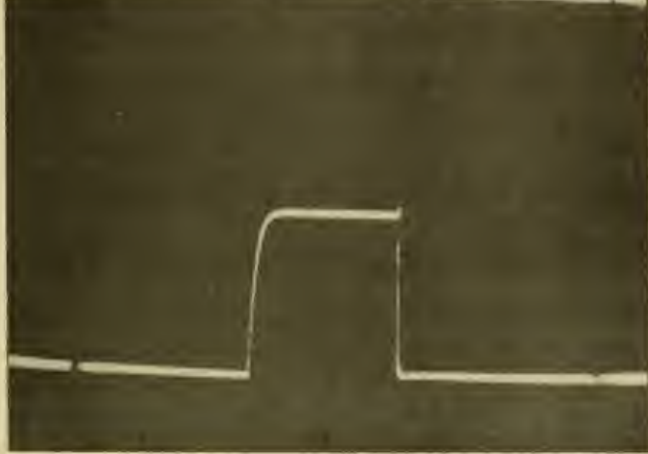

B. Plate Output Pulse



C. Near-coincident
Triggering Pulses
(Markers are 12 us.
apart)

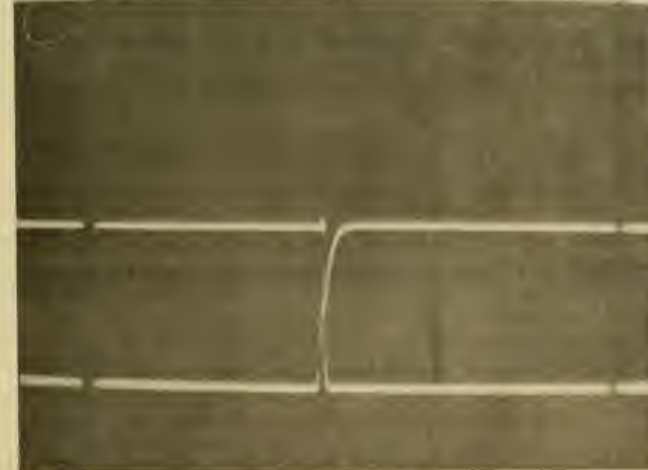

D. Resolution Limit
of Circuit

Figure 39
Oscillograms of two 50B5 Tubes Toggle Circuit

requirements implied. The plate current would be between ten and twenty amperes per bank, with heater and bleeder resistor losses in proportion; hence the chief application of this development may be in control-circuit pulsers, etc.

IX.16 Performance of the 6AK6.

Trials were made of this tube in the standard binary circuit having appropriate constants. The maximum repetition rate achieved was in the vicinity of two megacycles, so that the advantage over the 6J6 is but slight.

IX.2 CATHODE COUPLED BINARY CIRCUIT.

An experimental circuit was also developed from the conventional cathode-coupled multivibrator circuit; this is shown in sketch 2. This circuit was built using the 6J6 tube and performed at quite high speed - on the order of two or three tenths of a microsecond. Notice that it is not a true binary counter, for the cathode has two stable D.C. voltage levels. The advantages of the circuit are 1) that only one transverse-time-constant and one tube reaction time need be considered, 2) that useful energy may be supplied to the system in one direction from the pulsing source. The disadvantages of the scheme are that it was not symmetrical either in transfer susceptibility or in stable states, and in fact it was quite critical of operating conditions.

IX.3 THYRATRON CONTROL RECOVERY TIME.

As a matter of passing interest some experiments were carried out to determine a sort of minimum recovery time for miniature argon-filled thyratrons. The scheme was as follows: at any time after ignition, place a strong negative bias on the grid, and then dip the plate negative, determining the minimum dwell at the expiration of which the plate may be returned to positive potential

to find the grid has regained control. The point is obviously to determine what minimum time is necessary - not to de-ionize the tube - but to allow an electrostatic gradient to establish at the grid, separating the ions and electrons and allowing them to neutralize later. This minimum time was found to vary appreciably among tubes, but in some cases, at grid potentials of -150, was as short as 7 or 8 microseconds.

IX.4 NON-LINEAR PASSIVE COUPLING ELEMENTS.

Studies were also made of miniature glow tubes (neon) and crystal rectifiers (1N34) as coupling elements. Clearly these devices can be used to great advantage in various binary units. The ideal performance for such units is strictly rectangular voltage response; that is, infinite resistance up to a definite point and zero resistance thereafter. In addition it is desirable that reactance be as close to zero as possible. The glow tube is not only non-linear but its characteristic has an overshoot and a negative slope region at the point of angularity; also this occurs at a voltage different from zero, so that the glow tube equivalent circuit is a voltage-battery plus a peculiar rectifier. The only practical uses of glow tubes in high frequency is in cases where they may be ionized at all times, the rectinlinearity occurring when the applied voltage drops below the ionization potential for intervals shorter than the deionization time. Such applications occur in certain binary limiters and coupling applications.

IX.41 Glow Tube Possibilities.

Some tests along these lines were made on neon glow tubes. It was found possible to use them as coupling elements where the potentials are not critical, but that the performance variation with temperature and among

individuals of commercial manufacture was often as high as twenty percent in voltage.

IX.42 Crystal Rectifiers.

These tests were made on the Sylvania 1N34 and satisfactory results were indicated throughout the range covered (up to 10 megacycles). Some mechanical breakage and variation in forward to back ratio was encountered, but in general these units seem most promising. Their use is further discussed in Section 11.

IX.5 ANTISYMMETRICAL PULSING; STUDY OF TRANSFER.

The tests conducted on conventional Eccles-Jordan binary elements, and the analysis of the transfer process during symmetrical pulsing brought up many questions thought to be quite fundamental to the process of storage and transfer between and among binary cells. A different view of the process - novel and profitable at least to the members of our group - was gradually evolved, and is sketchily outlined here. The framework of a rather comprehensive and satisfying method of analyzing electron-tube binary element performance graphically and experimentally has been developed, and it is expected that at some later date this may be detailed in a monograph.

IX.51 Memory During Transfer.

It is clear from the outline of IX.11 that the role of the transpose condensers in the Eccles-Jordan binary circuit is to remember the prior state of the element during transition. No other excuse exists for their presence; under all circumstances they contain the last hangover from the previous state to be cleared, so that they are the limiting factor on speed. In fact they constitute a crude means for carrying out a very critical frequency-discriminating operation using linear elements; namely, a separation between the time constants

of the two tube reactions, and the pulse characteristic on the one hand, and the desired repetition rate on the other. Variations among tubes, also due to circuit wiring and to deterioration of pulse shape when driving multistage networks, etc., are almost certain to require relaxing this sharp discrimination by increasing time margins.

These difficulties result from the notion that the binary cell must be transferred directly by merely an order without sign. If this notion is abandoned, and the view adopted that the binary cell be ordered to change to a certain state, then the need for transposition memory evaporates and all impedances except those parasitic to the network can be eliminated.

Consider what is meant by the question of "reaction time delay" when a network having two sets of terminals A and B is required to exchange states by an outside means capable of impressing the voltages formerly at B or A or vice versa. Clearly if the command circuit is of low impedance, the new state can be made to exist as nearly instantaneously as desired, upon carrying out the switching operation. If the states A and B both happen to be stable, then the result is stable when established (except for propagation phenomena within the network) and the command circuit may be removed without relapse. If energy is required to transfer, then this may be supplied from the central command circuit during transfer.

IX.52 Transfer Order with Sign.

The process of transfer can then be conceived in two steps.

- 1) Sensing the state of the binary cell to be transferred, by using it to command the state of another (temporary memory) cell.

- 2) Re-impressing this binary cell upon the original in reverse sense.

In this way the sign of the transfer is sensed from the present state of the binary cell by another binary cell (rather than by a linear R-C cell) and then this inforced cell commands the original.

IX.53 Transfer Cycle vs. Transfer Pulse.

The question of energy and time enter this picture in an illuminating way. Consider a binary cell consisting of a pair of electron tubes and a pure resistance network; this had two D.C. stable states and (unfortunately) various parasitic capacitances. Energy is required to transfer it from one state to the other; the command voltages must exist for a finite duration through a finite amplitude, for finite plate-reaction times. The energy required to trip the circuit will be very different if applied at the grid terminals compared to the plate terminals. Calling these respectively input and output terminals, their ratio is an energy sensitivity, and the resistance network may be so designed as to maximize this parameter. If the output terminals of one such circuit be impressed on the input terminals of another such circuit by some means then the more sensitive circuit will transfer to conform to the state of the insensitive circuit; the transfer will always be in that direction if the sensitivity ratio is less than unity, the only variation with ratio being in reaction time since near unity ratio both elements at juncture come near the vicinity of indecision. Hence the switching can be gradual or instantaneous, and if instigated by a pulse, this may be of any shape whatever except that it exceed a minimum amplitude for the minimum reaction time of the elements. Hence the pulse can conveniently be thought of

as a cycling sequence.

IX.54 Amplitude vs. Time Sensitivity.

Whereas in fact energy is required to change the state of the electron-tube binary cell, in an indirect sense the system is conservative. In particular the two halves of the system are perfectly symmetrical, and the end points are the same; hence except for a constant parasitic standby energy loss the system has the same potential in both states. It may be noted in passing that if either a grid lead or plate lead be moved from state A to state B at slow constant rate, a milliammeter series will execute a closed excursion, so that the energy drawn from the source of the order may, under certain circumstances, be zero. The circuit has clearly become more nearly binary in an entropy sense.

A further point of practical interest: The sensitivity to change at either pair of terminals can be affected by altering the supply potentials to the system. Accordingly one cell can impress itself upon another of normally equal stability by reducing the plate voltage or increasing the negative grid bias of the receiver cell, thus reducing its threshold.

IX.6 6J6 PERFORMANCE ASSYMETRICALLY PULSED.

To verify these ideas a binary cell of conventional type using a 6J6 tube without transposition condensers was constructed and tested. Operated with the same supply potentials and resistance values as used in the test described in Section IX.12, and pulsed at each grid individually (through crystal rectifiers) first negative at the grid of the "on" tube, transferring the circuit, then negative at the grid of the other "on" tube, restoring it, the resolution time of the cell was found to be in the neighborhood of

.15 microsecond, it being impossible with available test apparatus to measure values in this vicinity. The rise time was estimated to be in the vicinity of .08 and the fall time something like .05 microsecond.

X. REGISTER COMPONENT STUDIES

X.1 PERFORMANCE CRITERIA.

A shifting register should be able to shift entire 40 binary digit entries in each direction one step at time and at the highest possible rate (preferably in a microsecond or less) and be able to accept and receive entire entries simultaneously from another 40 cell component at nearly the same rate.

X.2 6J6 SHIFTING REGISTER WITH GATES AND CONDENSER MEMORY.

Using standard centrally pulsed 6J6 Eccles-Jordan cells, a six stage shifting register was experimentally constructed and tested. R-C transposition networks were used, together with triode gates, one for each shift direction per stage (see sketch 4). This was operated successfully at rates up to two to three microseconds per shift, but was somewhat critical of pulse shape.

X.3 BROWN-RAJCHMAN SHIFT SCHEME.

Drs. Brown and Rajchman of RCA Laboratories have developed an R-C method of propagating information pulses without using electron tubes in each gate. This is indicated in sketch 5; it consists of an R-C circuit "suspended" between two crystals. The condenser gradually assumes the state of the cell to be propagated, and pulsing the crystals causes this value to be "picked up" and propagated to the next point. An experimental six stage shifting register was built incorporating this feature; performance was comparable to that of X.2 above, and further work was deferred by the development indicated in X.5-X.7 to follow.

X.4 PULSE PROPAGATION SHIFT SCHEMES.

Conceivably schemes may be devised whereby binary cells may be coupled by RC circuits and shifting accomplished by careful attention to the type of pulses applied to the system and to their points of application. Such schemes take the optimistic view that information as to state can be transposed simultaneously from all binary cells into the intervening coupling elements, retained there while clearing occurs, and caused to command the cell next in line (which has thus been cleared) to take on the stored state. Attempts of this sort were made from time to time in our experimental program and some intermittently successful units were occasionally hit upon, but the approach was abandoned as unlikely to lead to reliable apparatus.

X.5 TRANSFER BETWEEN "LOCKED" ELEMENTS.

The next stage of evolution of shifting circuits are those in which conventional Eccles-Jordan Toggles are used, not only as the main register binary storage cells, but also as positive memory intermediary storage between register cells. In such use the intermediary cells can be operated in various fashions with triode or crystal or other gates, or RC coupled to the cells on both sides. Such arrangements doubled the size of the register-memory component, but have the advantage that every other cell is "normally cleared" during stand by so that it can receive information from its neighbor at any instant without having to be cleared. Hence R-C transpose coupling can be used between cells with very much greater freedom as to time-discriminating performance. Schemes of this sort were tested and found capable of operation at rates near 2 or 3 microseconds per shift, but they were somewhat critical and were set aside in favor of developments along the lines of IX.6 above.

X.6 TRANSFER BETWEEN COUPLED, ASSYMETRICALLY PULSED 6J6'S.

In Sketch 6, a type of transfer-shifting circuit is indicated which is devoid of capacitances and time-constants, except those parasitic to the tube elements and wiring. This scheme involves emphasis of amplitude-sensitive coupling in keeping with the credo of sections II.61 and IX.54; the coupling elements being 1N34 Sylvania crystal diodes. The operation of the scheme may be seen to be (IX.53) that of drawing information from the N^{th} register stage into an intermediary (identical) stage, from which it is impressed on the $N+1^{\text{th}}$ stage. (It could also be re-enforced upon the original stage in reverse, so that a binary-counter would result.) The command comes from a single, powerful pulse source; the gates are amplitude sensitive crystals, and the ~~sign~~ is attached to the command by passing it through the educated shifter cell.

The ideas behind this scheme can better be approached by referring to sketch 7A. Here two binary cells are arranged to "talk" to each other upon command of a pulser. Amplitude-sensitive crystal rectifiers in T_{12} lines couple the sensitive side of Binary Cell No. 2 to the stable side of cell No. 1; similarly amplitude sensitive crystals couple T_{21} in opposite sense. The crystals have the property that no appreciable current passes when the cathode of the crystal is positive relative to the anode; the connections shown opportunely accomplish this when the system is in standby condition. Hence either binary cell can be placed in either state by some outside agency, such as the implanting of information an associated system of the same sort; the cells behaving as if the lines T_{12} and T_{21} did not exist. However if the cells be translated in voltage relative to each other,

as by pulsing P_1 positive relative to P_2 (recall IX.55 here) then information will be transferred from cell 2 to cell 1 and if the pulsing is reversed, the information will travel in the other direction, from cell 1 to cell 2. Note that "pulsing" here implies simply an excursion between P_1 relative to P_2 , and that this cycle is closed by returning P_1 and P_2 to their original states. The affair is therefore a binary counter. In practice it is not necessary to pulse at points P_1 and P_2 , since (as indicated in Sketch 3) the stability of a triode toggle is such that any of the supply busses +, 0, - may be swung relatively to the other two over a fairly wide range without upsetting the stability of the cell; and when this is done corresponding changes occur in the other electrode potentials capable of effecting the transfer. In particular, pulsing the cathode negative is convenient and effective.

This notion of toggle stability under translation of all electrodes proportionally, and of effecting stability by their relative shift, can be exploited more fully. For example, Sketch 3 indicated that if the relative shift between +, 0, and - supply busses is sufficiently great, the toggle passes beyond a "decision point" at which it ceases to have binary states; and that at this point the toggle may with trifling unbalance be caused to split into either state. Referring to Sketch 7E, if a pair of triode toggles are "suspended" between widely separated voltage busses E_{++} and E_{--} they may be translated through wide voltage ranges with little decrease in sensitivity by acting on all points 1, 2, and 3 in the same sense; however if relative shift be accomplished between these points the sensitivity of the toggle is affected. In this circumstance one toggle may be reduced to the point of indecision and the other toggle translated so that transfer occurs, and this

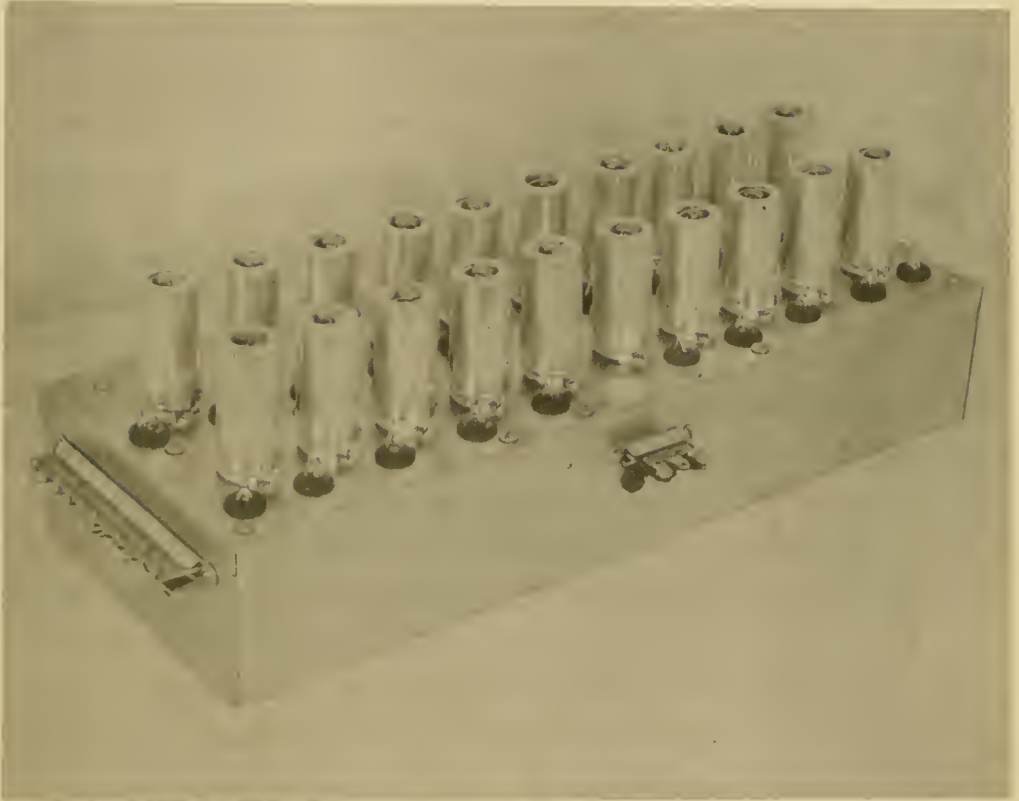

Figure 40
Ten Stage Shifting Register
(Positive-Locked Exchange Type)

may be accentuated enough so that coupling elements of linear type can be used in the leads T_{12} and T_{21} ; in fact, resistors or condensers will work very well. Further, by proper design the condition of transfer can be so maximized that the pulsing program amounts simply to driving one of the toggles into the vicinity of its non-binary state and then returning. Further work on circuits of this type is being carried out.

Another variant which is of interest is the "clave" coupling systems indicated in sketch 7B. Here the inside toggle is forced to obey the outside toggle in the "normal" state, but when swung negative by cathode pulsing it is freed from the bond and impresses itself upon the outer toggle, thus changing its state. Circuits of this sort have been operated at rates of about .3 microsecond for the entire cycle; circuits of the type indicated in 7A have been operated at rates in the vicinity of .15 microsecond, the uncertainty being due to inadequate resolution in the apparatus used for the measurement.

X.7 POSITIVE SHIFT AND TRANSFER 6J6 REGISTER:

A register designed along the lines of Sketch 7C has been built in 10 stages and tested experimentally; it is pictured in Figure 40. This register was found to operate successfully in that it shifted in about one-half microsecond. Tests are still being conducted to determine and maximize the performance beyond this point, and further circuit study is in progress to relax tolerances on components, supply voltages, etc. but it is considered to be a very promising solution to the problem of designing arithmetic components.

It is clear that work to date on arithmetic organs has been primarily at the level of elementary binary components, and that the full possibilities in combinations of these positive transfer components is by no means adequately covered by this report. Various combinatorial arrangements are clearly possible, and some are represented in Sketches 7C, D.

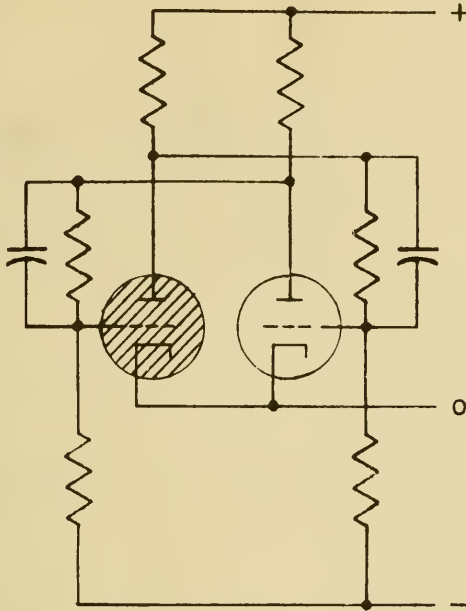

CONVENTIONAL ECCLES-JORDAN BINARY CELL
SKETCH 1

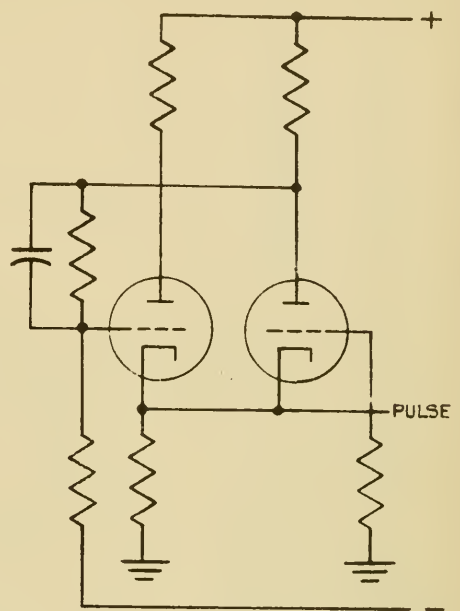

CATHODE-COUPLED BINARY CELL
SKETCH 2

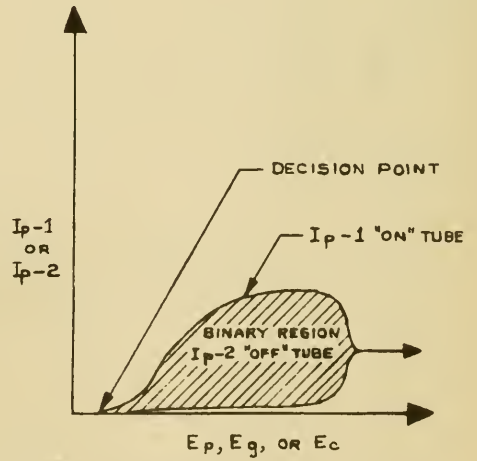
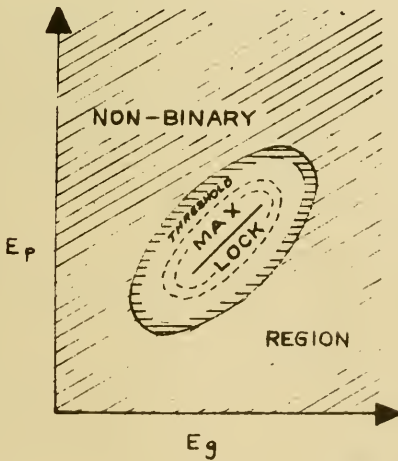

ELECTRON-TUBE BINARY CELL STABILITY
SKETCH 3

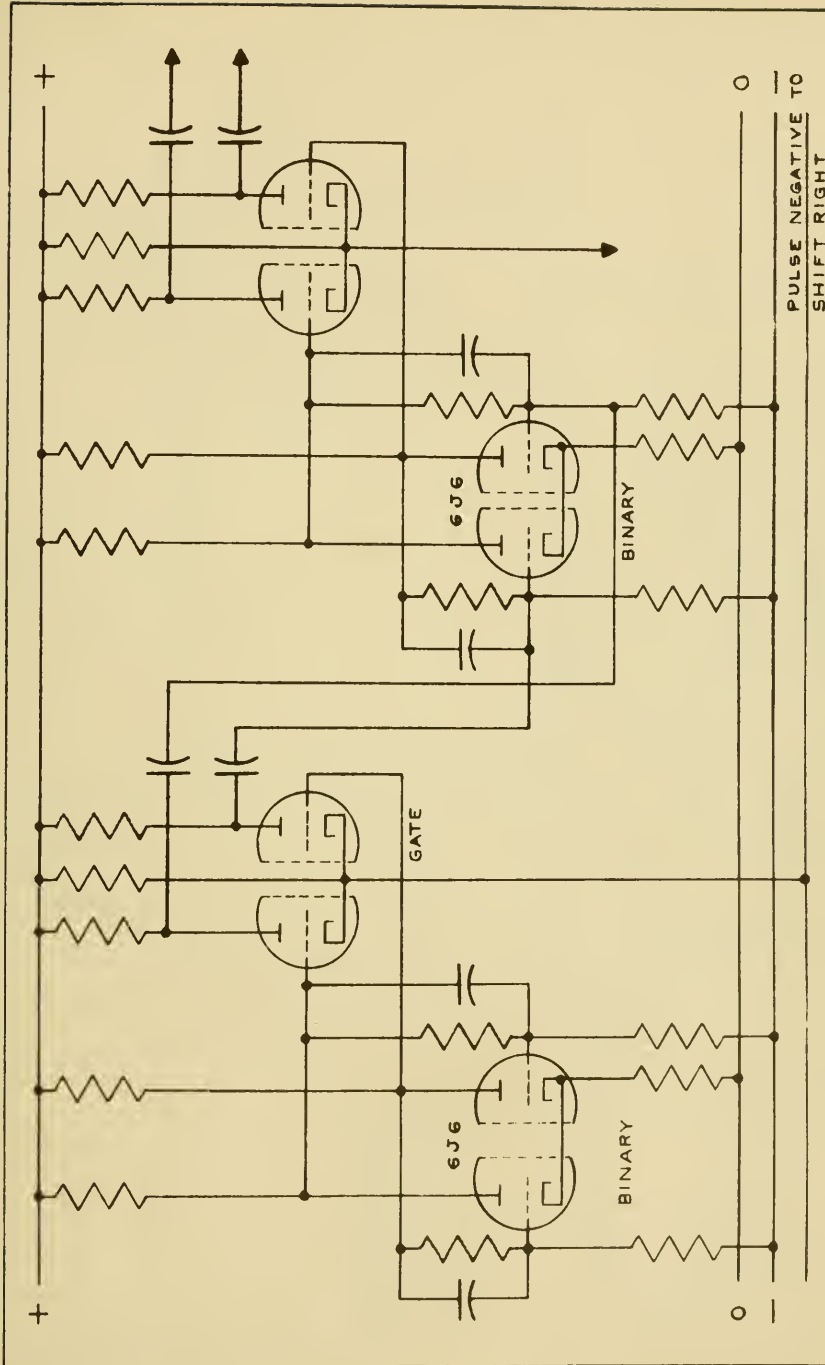

CONVENTIONAL REGISTER WITH TRIODE GATES AND R-C TRANSITION MEMORY (SHIFTS RIGHT)

SKETCH 4

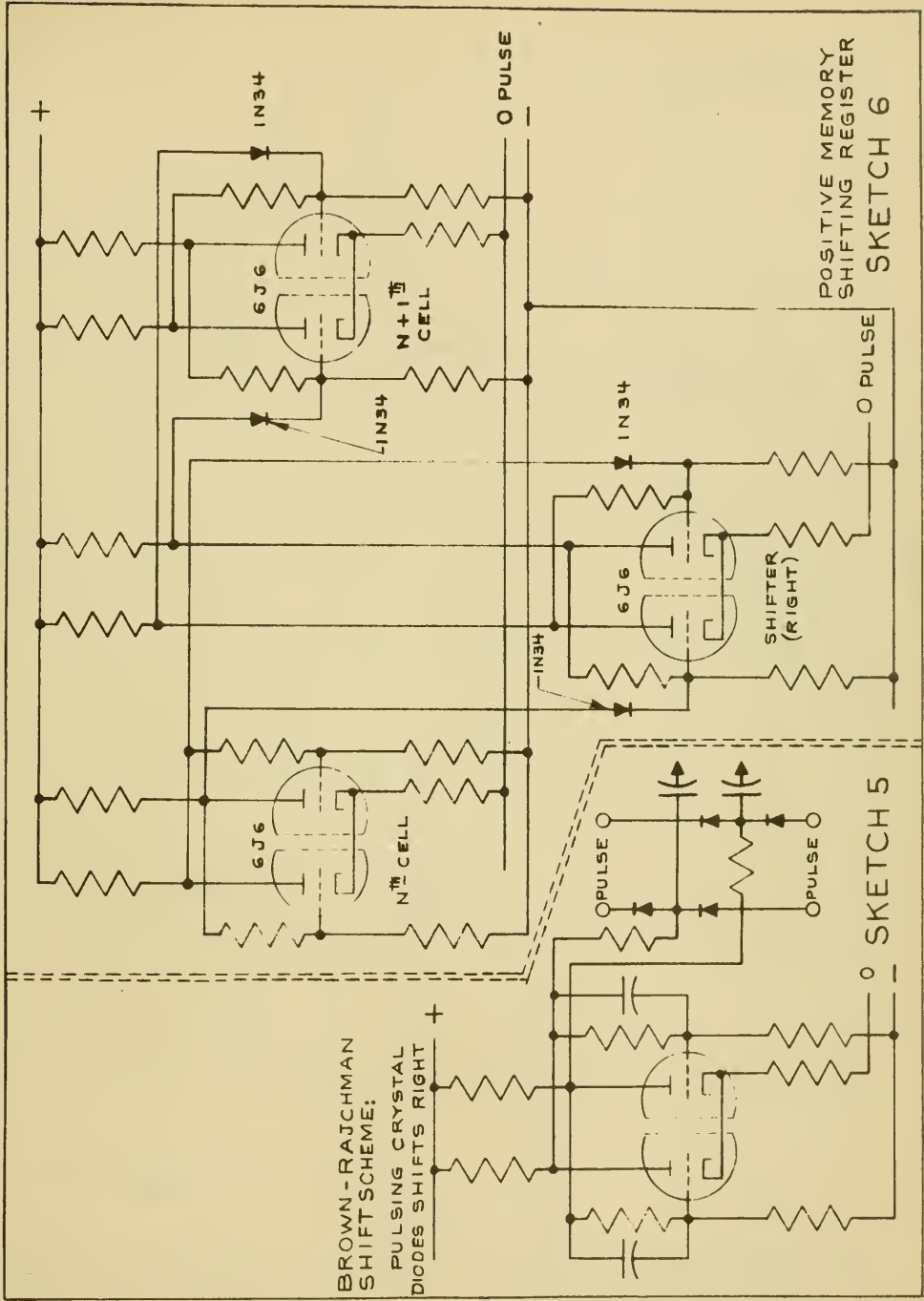

BROWN-RAJCHMAN
PULSING CRYSTAL
DIODES SHIFTS RIGHT

POSITIVE MEMORY
SHIFTING REGISTER
SKETCH 6

SKETCH 5

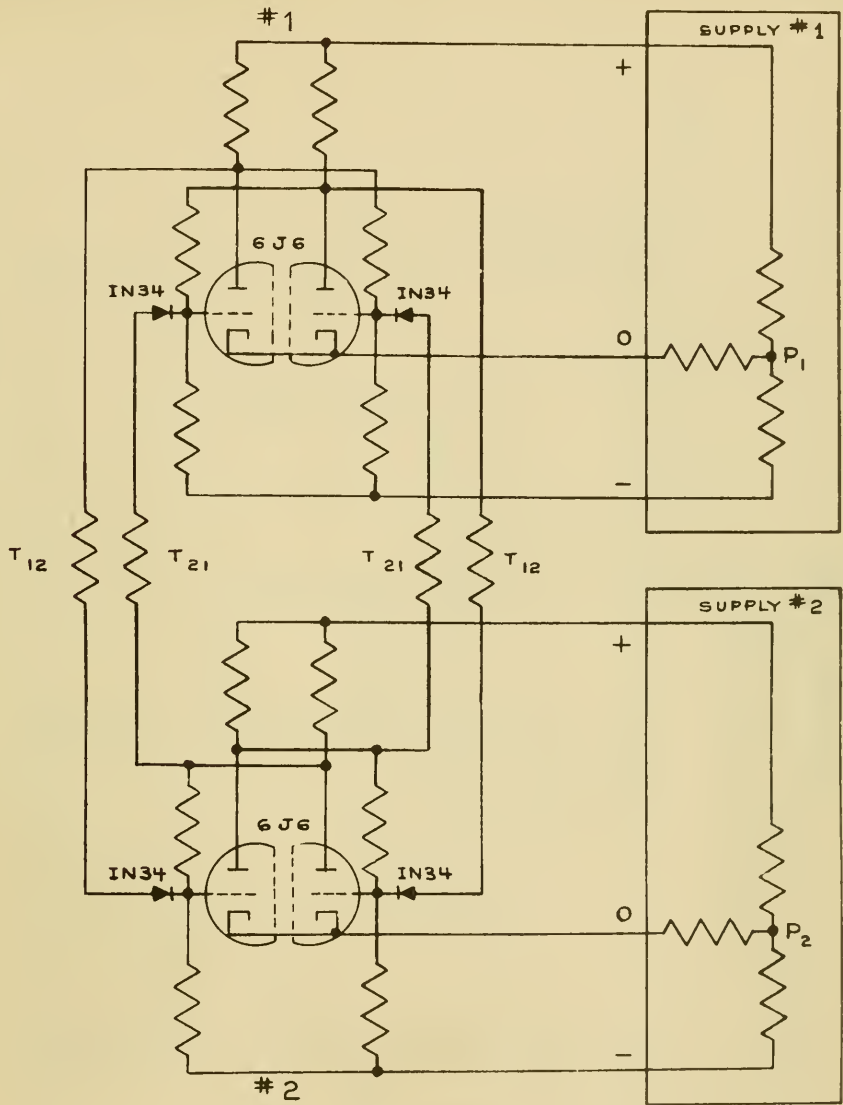

7A PROTOTYPE SCHEME

SKETCH 7A

(TYPICAL COMBINATORIAL USE OF ASYMMETRICALLY DRIVEN BINARY CELLS)

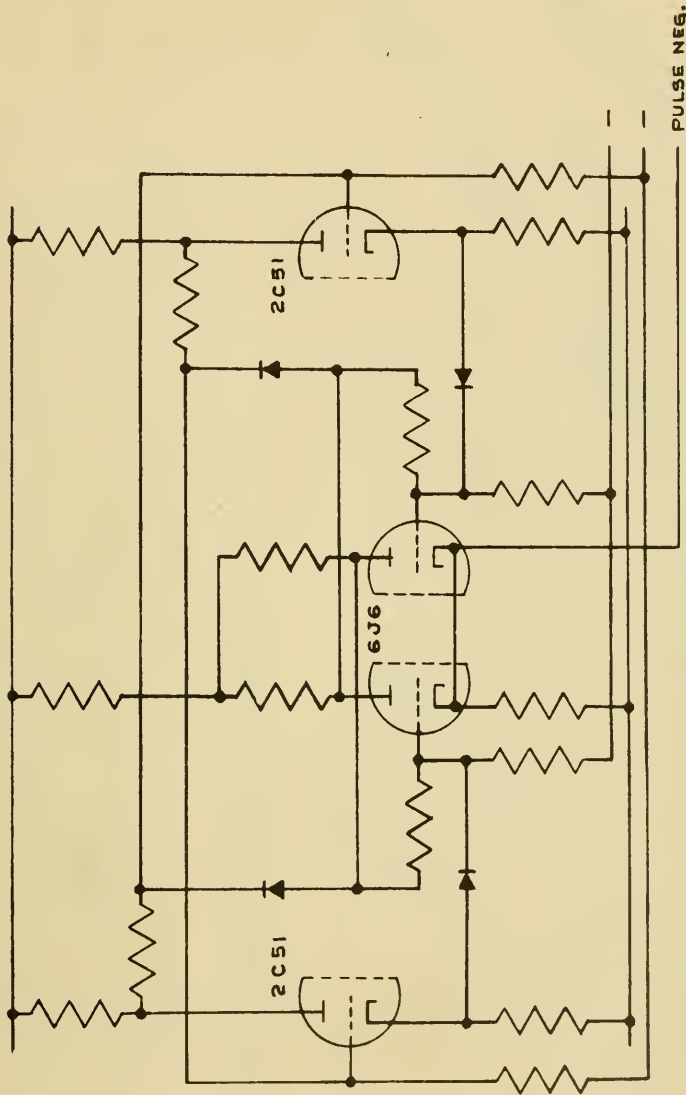

ARRANGED AS BINARY COUNTER

7B TYPICAL VARIANT : SLAVE SHIFTER

SKETCH 7B

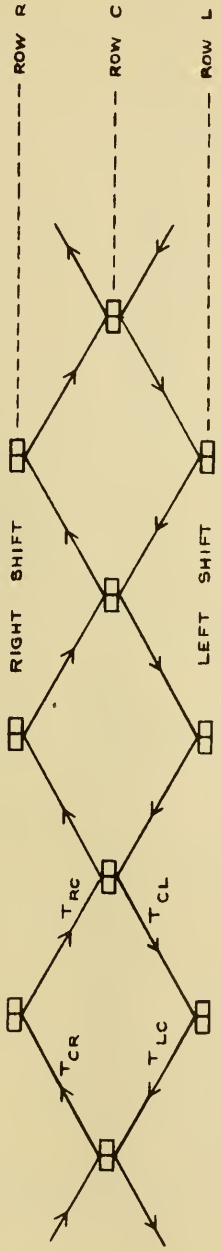

7C TYPICAL COMBINATORIAL POSSIBILITY
BILATERAL SHIFTING REGISTER

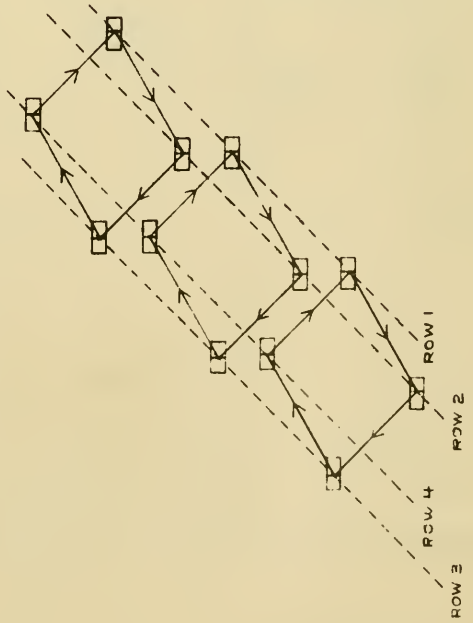

CIRCULAR EXCHANGE

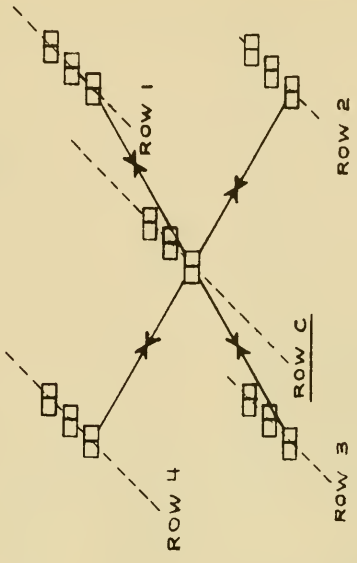

CENTRAL EXCHANGE

7D TYPICAL COMBINATIONS OF COMMUNICATIVE BANKS OF CELLS
SKETCH 7C, 7D

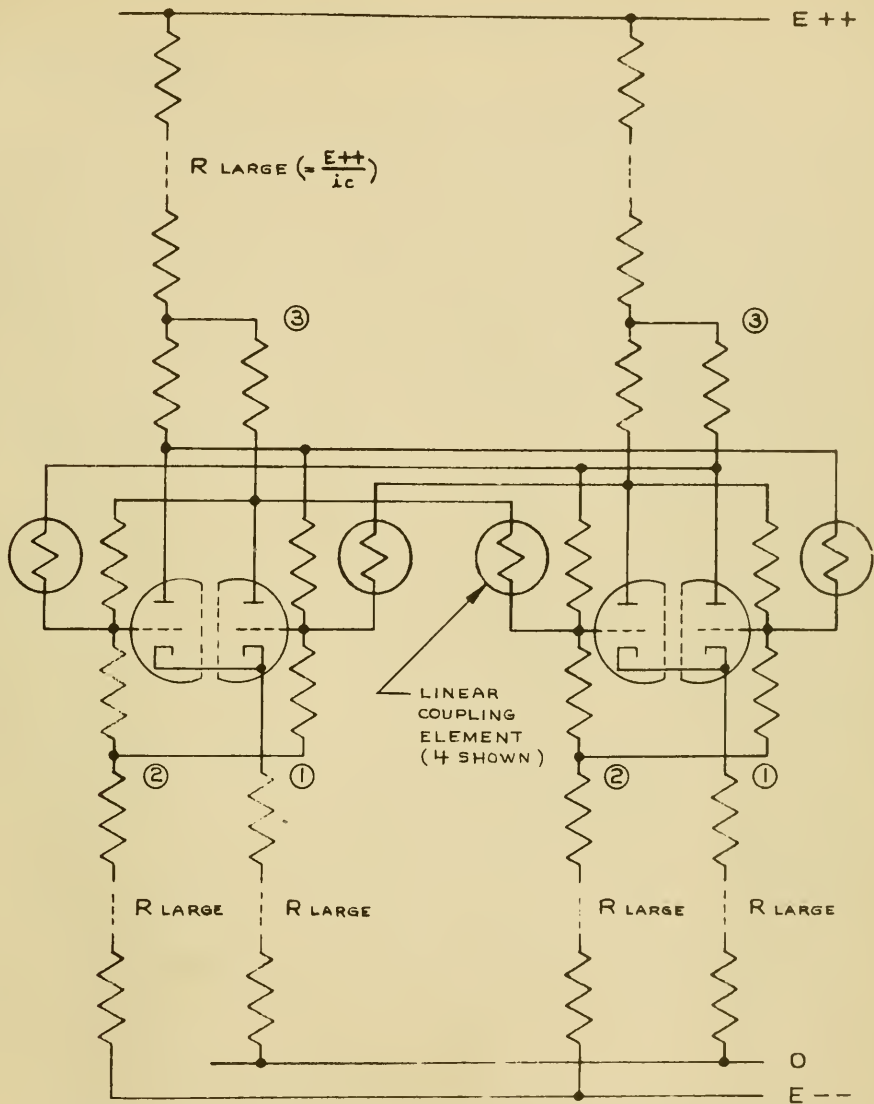

NOTES:

TRANSLATION BY SWINGING POINTS ①, ②, ③ SIMULTANEOUSLY DOES NOT TEND TO UNLOCK TOGGLE.
 RELATIVE SHIFT OF POINTS ① ≠ ② ≠ ③ DOES AFFECT LOCK THRESHOLD OF TOGGLE.

CIRCUIT TO ILLUSTRATE EFFECTS OF SWINGING LOCKED BINARY CELLS

SKETCH 7E

XI. IMMEDIATE PROSPECTUS

XI.1 SHIFTING REGISTER:

It is clear that the development up to 1 January 1947 date covered by this report have been primarily on the input-output organs, and upon the elementary "cell" studies of the arithmetic organs. As the work progresses and the development personnel become more of a team and a better understanding of the technical and entire problem infiltrates these teams, more attention can and should be given to general planning and organization of the machine; such as, for example, is required by programming and control.

XI.2 SHIFTING REGISTER AND ACCUMULATOR

Further development and testing of systems of components capable of carrying out these arithmetic operations rate first priority. It is considered that the understanding and development of positive-lock transfer elements gained to date place us in a very strong position to design and construct adequate register and accumulator components. An experienced team is working on this full time.

XI.3 DETAILED DESIGN OF INPUT, OUTPUT AND OUTER MEMORY ORGANS.

Work in these directions has progressed to the point where design and construction of the organs for the first model can proceed. A competent team is devoting full time to the indexing, interpreting and controlling of N_2 , and an experienced designer-draftsman is drawing up working layouts for N_2 storage and drive.

XI.4 EXPLORATORY STUDY OF CONTROL ORGAN.

To date, some work has been done on the control organ, but it is clearly less advanced than the arithmetic and N_2 organs. Since the group has moved recently to new quarters and an adequate shop set up developed,

:

and further since two new members have joined the engineering staff to replace those who left in October, it is quite clear that the control problem can not be attacked effectively by a team having this as their primary objective. It is therefore expected to be possible to proceed on the terminal organs, the arithmetic organs and the control organs concurrently, and to advance in these three directions at more rapid rates.

Faint, illegible text at the top of the page, possibly bleed-through from the reverse side.

22/11/11
1



(3) 47043

Institute for Advanced Study.
Electronic Computer Project.
Interim progress report.
v.1

DATE	ISSUED TO
FE 18 '58	S & K 2234 Green
May 5, 1960	INTERLIBRARY LOAN
	<i>Paul Steg</i>
	INTERLIBRARY LOAN
14 Mar '67	Duke Univ. Library - IBM
2/20/73	<i>NY</i> <i>St. Louis, Mo.</i> <i>Magard, Res.</i>

47043

Institute for Advanced Study
Math. - Nat. Sci. Library
Princeton, N. J. 08540

